

→ Series Hygienic 400

Hygienic 400

Safety valve made of stainless steel, angle type, with stainless steel spring



■ MATERIAL



■ SPECIFICATION



■ SUITABLE FOR

Liquids	neutral and non-neutral	
Air, gases and vapours	neutral and non-neutral	
Steam		

■ EXAMPLES OF USE

For the protection of:

- processes, plants and containers in the food and pharmaceutical industry for air, neutral and non-neutral vapours and gases, steam and liquids taking into account the operation- and plant-specific regulations and making use of the suitable valve version and sealing material.

- Food industry
- Breweries and beverage industry
- Pharmaceutical industry
- Cosmetic industry
- Medical technology
- Clean Service applications

■ FEATURES

- Smooth and faultless surface finish optimized for cleaning process
- Minimal dead space in inlet area and no gaps in the valve
- Exposed and rinsed o-ring seals
- Shape of valve body avoids forming of puddles in the valve
- Adjustable and settable during operation
- Possible to carry-out CIP/SIP by lifting the disc from the seat
- Gap-free installation of seals
- Surface roughness in the primary area Ra < 0.75µm
- Optional: electropolished and/or mechanically polished
- Moulded diaphragm for separating the product space from the springhousing
- Dead space ratio L/D ~ 1,5

For explanation see chapter 1.1 General information on the hygienic valves. Definition of surface quality and options according to Chapter 1.1 Table V-301.

■ APPROVALS

TÜV-Type test approval 2062	D/G, F, F/K/S
EU type examination	S/G, L, F/K/S
TSG ZF001-2006	S/G, L, F/K/S
TR ZU 032/2013 - TR ZU 010/2011	S/G, L, F/K/S
Requirements	
DIN EN ISO 4126-1	TRD 421
PED 2014/68/EU	AD 2000 Data sheet A2
TRB 801 No. 22 and 23	KGS AA 319
Additional hygienic requirements	
EG No. 852/2004	GS-NG 2 and 5
DIN EN 1672-2	EHEDG Aseptik
9. GPSGV	
Classification society	
DNV	DNV
Bureau Veritas	BV
Russian Maritime Register of Shipping	RS
Registro Italiano Navale	RINA

■ MATERIALS

Component	Material	DIN EN	ASME
Body	Stainless steel	1.4435	316 L
Inner parts, wetted	Stainless steel	1.4435	316 L
Upper section, other inner parts	Stainless steel	1.4404	316 L
Spring	Stainless steel	1.4310	302
Bellows	Stainless steel	1.4571	316 Ti

b	Standard with bellows	for neutral and non-neutral media and/or counter pressure up to $\leq 30\%$ of the set pressure, but max. 4 bar. Spring, moving parts and the environment are protected from being affected by the medium.
----------	-----------------------	---

Parts which are difficult to clean in the guide, the spring housing and the spindle / disc combination are protected against soiling by stainless steel bellows

■ MEDIUM

GF	gaseous and liquid	Air, vapours, gases, liquids and - depending on safety valve version and seal - also for steam
-----------	--------------------	--

■ TYPE OF LIFTING MECHANISM

K	Standard with twist-type lifting mechanism
P	Pneumatic lifting device (available for valves with set pressure ≤ 8 bar)

■ AVAILABLE NOMINAL DIAMETERS AND CONNECTION SIZES

Nominal diameter DN		20								
Connection type		DIN				ISO			ASME	
Inlet DN (NPS)		DN 20	DN 25	DN 32	DN 40	DN 15	DN 20	DN 25	1"	1½"
Outlet DN (NPS)	25	■	■			■	■	■		
	32	■	■	■			■	■		
	40 (1½")			■	■			■	■	■
	50 (2")			■	■					■

You can find more connection types [here](#)

■ TYPE OF CONNECTION INLET / OUTLET

KLSDIN / KLSIDIN	Standard	Clamp connection / Clamp connection	DIN 32676 -A/ DIN 32676-A	Pipe Standard DIN 11850-2 / 11866-A
GS1 / GS1		Threaded ferrule connection / Threaded ferrule connection	DIN 11851 / DIN 11851	Pipe Standard DIN 11850-2 / 11866-A
KS1 / KS1		Taper nipple / Taper nipple	DIN 11851 / DIN 11851	Pipe Standard DIN 11850-2 / 11866-A
A-BKS1 / A-BKS1		Aseptic collar clamp connection / Aseptic collar clamp connection	DIN 11864-3 / DIN 11864-3 DIN 11853-3 / DIN 11853-3	Pipe Standard DIN 11850-2 / 11866-A
A-GS1 / A-GS1		Aseptic threaded ferrule connection / Aseptic threaded ferrule connection	DIN 11864-1 / DIN 11864-1 DIN 11853-1 / DIN 11853-1	Pipe Standard DIN 11850 / 11866
A-BF1 / A-BF1		Aseptic flanged connection / Aseptic flanged connection	DIN 11864-2 / DIN 11864-2 DIN 11853-2 / DIN 11853-2	Pipe Standard DIN 11850-2 / 11866-A

■ SEALS

FKM	Fluorcarbon	Elastomere moulded seal	FDA, USP, 3-A, ADI-free	-20°C to +200°C
EPDM	Ethylene propylene diene	Elastomere moulded seal	FDA	-40°C to +170°C

Series Hygienic 400: Connection, installation dimensions, ranges of adjustment											
Nominal diameter	DN	20									
Connection ¹⁾	Clamp connection DIN 32676-A				Threaded ferrule connection DIN 11851-SC						
Connection inlet	DN1	20	25, 32, 40	40	20	20	25	32	40	40	
	D1	34	50,5	50,5	-	-	-	-	-	-	
	G1	-	-	-	Rd 44 x 1/6	Rd 44 x 1/6	Rd 52 x 1/6	Rd 58 x 1/6	Rd 65 x 1/6	Rd 65 x 1/6	
	F1	-	-	-	-	-	-	-	-	-	
Connection outlet	DN2	25, 32	25, 32, 40	50	25	32	25	32	40	50	
	D2	50,5	50,5	64	-	-	-	-	-	-	
	G2	-	-	-	Rd 52 x 1/6	Rd 58 x 1/6	Rd 52 x 1/6	Rd 58 x 1/6	Rd 65 x 1/6	Rd 78 x 1/6	
	F2	-	-	-	-	-	-	-	-	-	
Installation dimensions in mm	L1	64	64	58	-	-	-	-	-	-	
	L2	-	-	-	99	102	99	102	103	105	
	L3	-	-	-	-	-	-	-	-	-	
	L4	-	-	-	-	-	-	-	-	-	
	h1	34	34	34	-	-	-	-	-	-	
	h2	-	-	-	58	58	63	66	67	67	
	h3	-	-	-	-	-	-	-	-	-	
	h4	-	-	-	-	-	-	-	-	-	
	H1	145	145	145	145	145	145	145	145	145	
	H2 ³⁾	176	176	176	176	176	176	176	176	176	
	H3 ³⁾	157	157	157	157	157	157	157	157	157	
	S	6	6	6	6	6	6	6	6	6	
	Compressed air connection in mm	S	6	6	6	6	6	6	6	6	6
Performance values		$\alpha_w/K_{dr}(F)^{2)}$	0,4	0,4	0,4	0,4	0,4	0,4	0,4	0,4	0,4
		$\alpha_w/K_{dr}(D/G)^{2)}$	0,55	0,55	0,55	0,55	0,55	0,55	0,55	0,55	0,55
do	18	18	18	18	18	18	18	18	18	18	
Weight	kg	1,8	1,8	2,0	1,9	1,9	2,0	2,0	2,2	2,3	
Range of adjustment	bar	0,4 - 16	0,4 - 16	0,4 - 16	0,4 - 16	0,4 - 16	0,4 - 16	0,4 - 16	0,4 - 16	0,4 - 16	

Series Hygienic 400: Connection, installation dimensions, ranges of adjustment													
Nominal diameter	DN	20						20					
Connection ¹⁾	Taper nipple DIN 11851-SD						Aseptic flanged connection DIN 11864-BF						
Connection inlet	DN1	20	20	25	32	40	40	20	20	25	32	40	40
	D1	-	-	-	-	-	-	-	-	-	-	-	-
	G1	Rd 44 x 1/6	Rd 44 x 1/6	Rd 52 x 1/6	Rd 58 x 1/6	Rd 65 x 1/6	Rd 65 x 1/6	-	-	-	-	-	-
	F1	-	-	-	-	-	-	64	64	70	76	82	82
Connection outlet	DN2	25	32	25	32	40	50	25	32	25	32	40	50
	D2	-	-	-	-	-	-	-	-	-	-	-	-
	G2	Rd 52 x 1/6	Rd 58 x 1/6	Rd 52 x 1/6	Rd 58 x 1/6	Rd 65 x 1/6	Rd 78 x 1/6	-	-	-	-	-	-
	F2	-	-	-	-	-	-	70	76	70	76	82	94
Installation dimensions in mm	L1	-	-	-	-	-	-	-	-	-	-	-	-
	L2	-	-	-	-	-	-	-	-	-	-	-	-
	L3	92	95	92	95	96	98	-	-	-	-	-	-
	L4	-	-	-	-	-	-	68	95	68	95	95	95
	h1	-	-	-	-	-	-	-	-	-	-	-	-
	h2	-	-	-	-	-	-	-	-	-	-	-	-
	h3	52	52	56	59	60	60	-	-	-	-	-	-
	h4	-	-	-	-	-	-	59	59	58	59	59	59
	H1	145	145	145	145	145	145	145	145	145	145	145	145
	H2 ³⁾	176	176	176	176	176	176	176	176	176	176	176	176
	H3 ³⁾	157	157	157	157	157	157	157	157	157	157	157	157
	S	6	6	6	6	6	6	6	6	6	6	6	6
	Compressed air connection in mm	S	6	6	6	6	6	6	6	6	6	6	6
Performance values		$\alpha_w/K_{dr}(F)^{2)}$	0,4	0,4	0,4	0,4	0,4	0,4	0,4	0,4	0,4	0,4	0,4
		$\alpha_w/K_{dr}(D/G)^{2)}$	0,55	0,55	0,55	0,55	0,55	0,55	0,55	0,55	0,55	0,55	0,55
do	18	18	18	18	18	18	18	18	18	18	18	18	
Weight	kg	2,0	2,0	2,1	2,3	2,4	2,6	2,2	2,3	2,3	2,4	2,5	2,6
Range of adjustment	bar	0,4 - 16	0,4 - 16	0,4 - 16	0,4 - 16	0,4 - 16	0,4 - 16	0,4 - 16	0,4 - 16	0,4 - 16	0,4 - 16	0,4 - 16	0,4 - 16

¹⁾ Other connection types / sizes possible, dimensioning according to separate dimensional drawing.

²⁾ Coefficients of flow for D/G and F valid from 4.5 bar. For lower pressures, see specifications in the performance table.

³⁾ Details for version with pneumatic lifting.

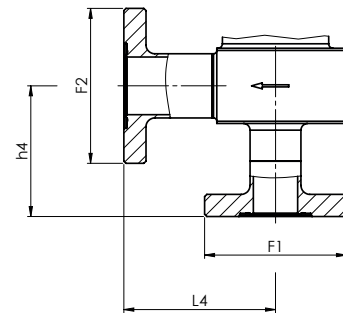
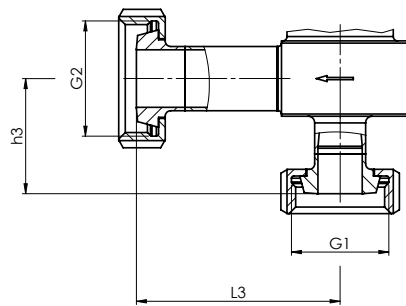
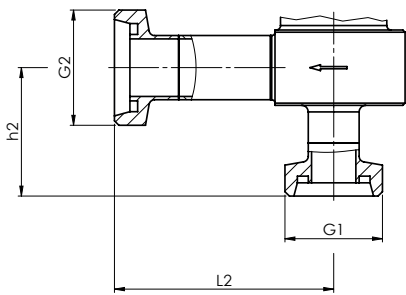
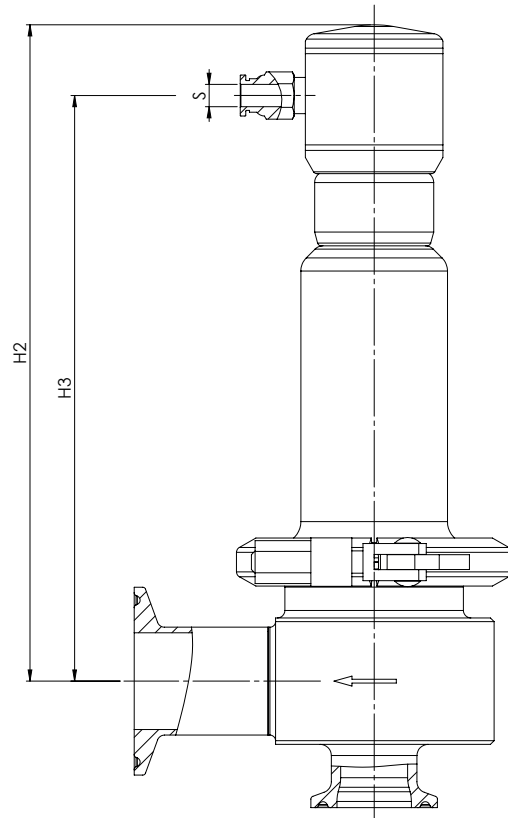
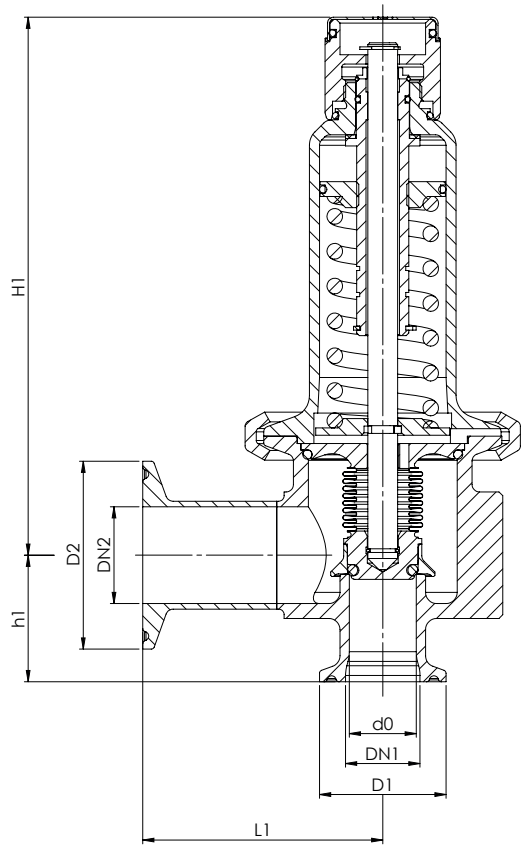

Series	Valve version	Medium	Lifting device	Nominal diameter DN	Connection type		Connection type		Seal	Options	Set pressure
					Inlet	Outlet	Inlet	Outlet			
400	b	GF	K	20	GS1	GS1	25	25	FKM	P09	2,5
400	b	GF	K	20	KLSDIN	KLSDIN	25	25	EPDM	P07	3,2
400	b	GF	K	20							
400	b	GF	K	20							
400	b	GF	K	20							

■ PROPERTIES

DEFINITION OF SURFACE QUALITY AND OPTIONS ACCORDING TO CHAPTER 1.1 TABLE V-301

P01	Oil- and grease-free production	<input type="checkbox"/>	<input type="checkbox"/>
P05	Quality of surfaces in contact with media in inlet Ra ≤ 0,375	<input type="checkbox"/>	<input type="checkbox"/>
P07	Electropolished surfaces	<input type="checkbox"/>	<input type="checkbox"/>
P09	Surfaces mechanically and electropolished	<input type="checkbox"/>	<input type="checkbox"/>

■ CERTIFICATES / APPROVALS

C01	Factory certificate acc. DIN EN 10204 2.2 (WKZ 2.2)	<input type="checkbox"/>	C06	ATEX evaluation acc. to 2014/34/EU	<input type="checkbox"/>
C02	Test certificate acc. DIN EN 10204 3.1 (WPZ 3.1)	<input type="checkbox"/>	C07	SIL evaluation relating to IEC 61508-2	<input type="checkbox"/>
C03	Material test certificate acc. DIN EN 10204 3.1 (MPZ 3.1) (pressure retaining part)	<input type="checkbox"/>	C09	Seat tightness test with helium, leak detection method under vacuum incl. Factory Inspection Certificate 3.1 acc. to DIN EN 10204	<input type="checkbox"/>
C04	TÜV/DEKRA individual inspection acc. EN 10204 3.2 (TÜV/DEKRA-APZ)	<input type="checkbox"/>	C10	Certificate of oil- and grease free production	<input type="checkbox"/>
C05	Sealing material Manufacturer certification (FDA, USP 3, 3-A,...), Please indicate description of certificate:	<input type="checkbox"/>			<input type="checkbox"/>

■ ADMISSIONS / ACCREDITATIONS

AA1	EC Type examination acc. to Directive 2014/68/EU	<input type="checkbox"/>	AK1	Det Norske Veritas (DNV) type approval	<input type="checkbox"/>
AA2	TÜV component test acc. to VdTÜV specification sheet SV 100	<input type="checkbox"/>	AK2	Lloyd's Register (LR) type approval	<input type="checkbox"/>
AA4	EAC - certificate/declaration with passport for the valve and laser marking of the valve	<input type="checkbox"/>	AK3	American Bureau of Shipping (ABS) type approval	<input type="checkbox"/>
AA5	Manufacture License of Special Equipment People's Republic of China (ML)	<input type="checkbox"/>	AK4	Bureau Veritas (BV) type approval	<input type="checkbox"/>
	<input type="checkbox"/>		AK5	Russian Maritime Register of Shipping (RMRS) type approval	<input type="checkbox"/>
	<input type="checkbox"/>		AK6	Registro Italiano Navale (RINA) type approval	<input type="checkbox"/>
	<input type="checkbox"/>		AL	Individual inspection by notified body inspector – (body to be indicated):	<input type="checkbox"/>

■ ENQUIRY

Copy and send to: order@goetze.de.

Series Hygienic 400: Blowing-off rates at 10% above set pressure			
Nominal diameter DN		20	
		d0 = 18 mm	
Set pressure bar (g)	I	II	III
0,4	79,7	65,7	2,5
0,7	111,0	89,1	3,2
1,0	137,4	109,4	3,8
1,5	184,9	146,1	4,6
2,0	263,8	207,2	6,7
Air I	2,5	245,9	7,5
Nm ³ /h	3,0	302,5	9,1
	3,5	342,0	9,8
Steam II	4,0	381,9	10,5
kg/h	4,5	422,1	11,1
	5,0	477,4	12,1
Water III	5,5	516,7	12,7
m ³ /h	6,0	555,8	13,3
	6,5	595,1	13,9
	7,0	634,2	14,4
	7,5	673,3	14,9
	8,0	712,4	15,4
	8,5	751,4	15,8
	9,0	790,4	16,3
	9,5	829,4	16,8
	10,0	868,4	17,2
	11,0	946,5	18,0
	12,0	1024,4	18,8
	13,0	1102,1	19,6
	14,0	1180,2	20,3
	15,0	1258,3	21,1
	16,0	1336,1	21,8

Pressure-/ temperature rating

PN 16 | Material: 1.4404 / 1.4435

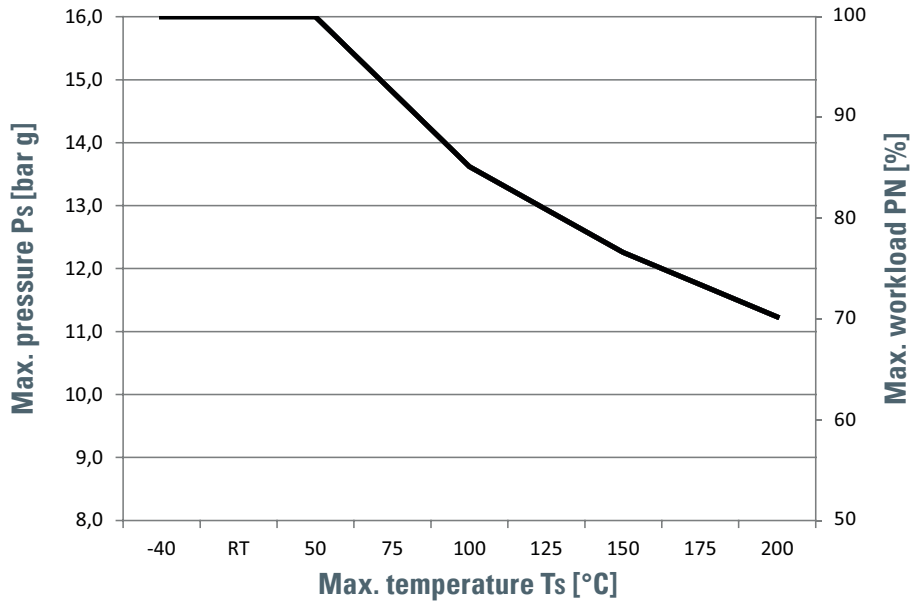

Control air pneumatic lifting device (max. 6 bar)

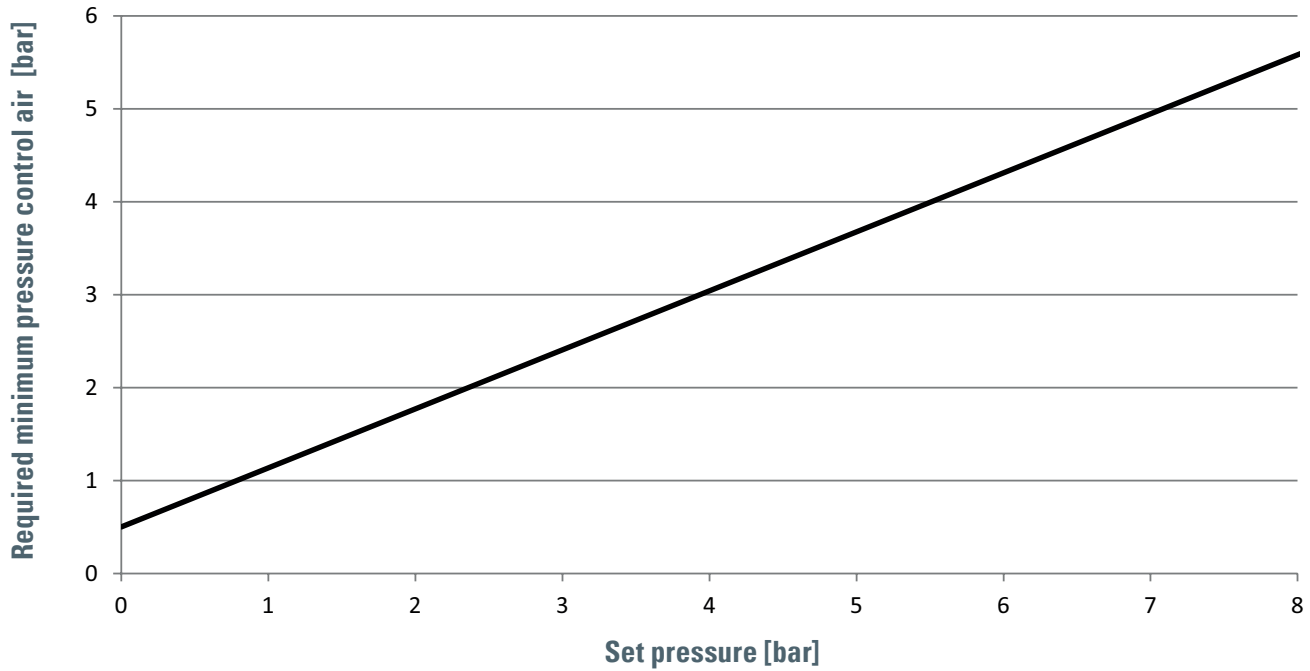

HYGIENIC AND ASEPTIC CONNECTIONS

Connection type	Drawing	Description	Standard	Pipe standard	400	400.5	4000	4020	4040	4060
KLSDIN KLSISO KLSASME KLSIX		Clamp connection Clamp connection Clamp connection Clamp connection	DIN 32676-A DIN 32676-B DIN 32676-C ISO 2852	Pipe standard DIN 11850-2 / 11866-A Pipe standard DIN EN ISO 1127 / DIN 11866-B Pipe standard BS 4825-1 / DIN 11866-C Pipe standard ISO 2037			X		X	X
GS1		Threaded ferrule connection	DIN 11851-SC	Pipe standard DIN 11850-2 / 11866-A			X		X	X
KS1		Taper nipple with groove cap nut	DIN 11851-SD	Pipe standard DIN 11850-2 / 11866-A			X		X	X
A-NKS1 A-NKS2 A-NKS3		Aseptic groove clamp connection Aseptic groove clamp connection Aseptic groove clamp connection	DIN 11864-3-NKS DIN 11864-3-NKS DIN 11864-3-NKS	Pipe standard DIN 11850-2 / DIN 11866-A Pipe standard DIN EN ISO 1127 / DIN 11866-B Pipe standard BS 4825-1 / DIN 11866-C			X		X	X
A-BKS1 A-BKS2 A-BKS3		Aseptic collar clamp connection Aseptic collar clamp connection Aseptic collar clamp connection	DIN 11864-3-BKS DIN 11864-3-BKS DIN 11864-3-BKS	Pipe standard DIN 11850-2 / DIN 11866-A Pipe standard DIN EN ISO 1127 / DIN 11866-B Pipe standard BS 4825-1 / DIN 11866-C			X		X	X
A-GS1 A-GS2 A-GS3		Aseptic threaded ferrule connection Aseptic threaded ferrule connection Aseptic threaded ferrule connection	DIN 11864-1-GS DIN 11864-1-GS DIN 11864-1-GS	Pipe standard DIN 11850-2 / DIN 11866-A Pipe standard DIN EN ISO 1127 / DIN 11866-B Pipe standard BS 4825-1 / DIN 11866-C			X		X	X
A-KS1 A-KS2 A-KS3		Aseptic collar connection with groove cap nut Aseptic collar connection with groove cap nut Aseptic collar connection with groove cap nut	DIN 11864-1-BS DIN 11864-1-BS DIN 11864-1-BS	Pipe standard DIN 11850-2 / DIN 11866-A Pipe standard DIN EN ISO 1127 / DIN 11866-B Pipe standard BS 4825-1 / DIN 11866-C			X		X	X
A-BF1 A-BF2 A-BF3		Aseptic flanged connection Aseptic flanged connection Aseptic flanged connection	DIN 11864-2-BF DIN 11864-2-BF DIN 11864-2-BF	Pipe standard DIN 11850-2 / DIN 11866-A Pipe standard DIN EN ISO 1127 / DIN 11866-B Pipe standard BS 4825-1 / DIN 11866-C			X		X	X
A-NF1 A-NF2 A-NF3		Aseptic grooved flanged connection Aseptic grooved flanged connection Aseptic grooved flanged connection	DIN 11864-2-NF DIN 11864-2-NF DIN 11864-2-NF	Pipe standard DIN 11850-2 / DIN 11866-A Pipe standard DIN EN ISO 1127 / DIN 11866-B Pipe standard BS 4825-1 / DIN 11866-C			X		X	X
SE4 SE5 SE6		Butt weld Butt weld Butt weld		Pipe standard DIN 11850-2 / DIN 11866-A Pipe standard DIN EN ISO 1127 / DIN 11866-B Pipe standard BS 4825-1 / DIN 11866-C					X	X
VC		Container flange at valve inlet							X	

Other connection types such as flange connection according to DIN EN 1092 / ASME B16.5, APV plain / grooved flanges, NA Connect, SMS threaded / tapered connection pieces are available on request.