

VISULEX Camera K55-4K-Ex



II 2G Ex db IIC T6 Gb
 II 2D Ex tb IIIC T80°C Db

Camera with fixed lens K55-4K-Ex

With these standard cameras, the lens is permanently adjusted to the object to be observed during installation (outdoor area/outdoor plant or process parts such as boilers or agitators).

Design and application:

- Pressure-resistant stainless steel housing with built-in colour CCD camera, 1/2.8", 0.08 Lux light sensitivity at F2.2; 40 IRE
- Approved for Ex zones 1 and 2 as well as zones 21 and 22
- Protection class IP 65

Application temperature range: 0°C to +40°C

EU type examination certificate: BVS 15 ATEX E 056 X



II 2G Ex db IIC T6 Gb
 II 2D Ex tb IIIC T80°C Db

Type of protection: Ex d

Explosion groups: IIC (includes IIA and IIB)
 IIC (includes IIIA and IIIB)

Lenses with focal length:

8 mm (39°); 6 mm (54°); 5.4 mm (60°)
 Minimum distance lens to object: 0.3 m

Electrical connection:

via the network cable (POE)
 IEEE 802.3af



VISULEX camera K55-4K-Ex mounted on a flange with a hinged bracket

Specification:

Image resolution max. 3840 x 2160 p

Control line:

Network cable cat. 7 Flex, max. 60 m, 4x2xAWG 26, part no. L#3461.002.00

Weight:

3.2 kg without network cable

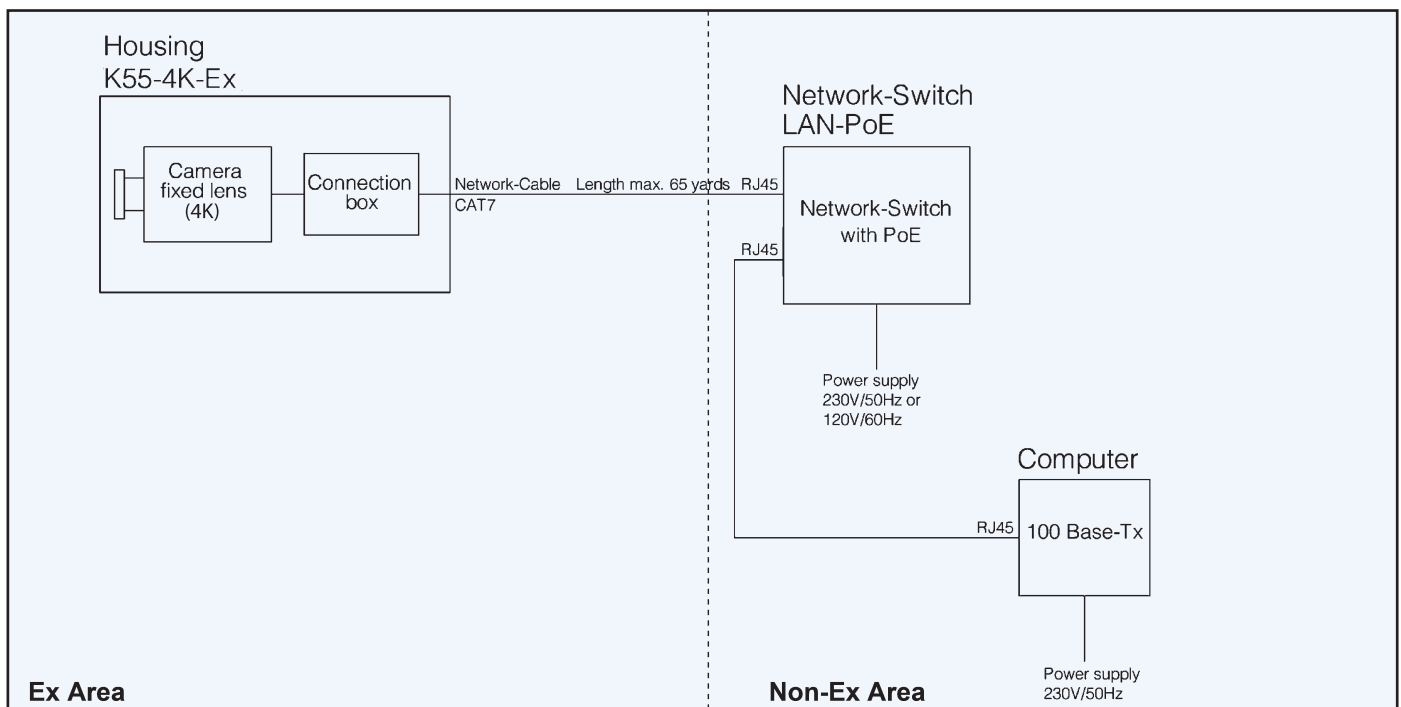

Dimensions and technical data for VISULEX Camera K55-4K-Ex

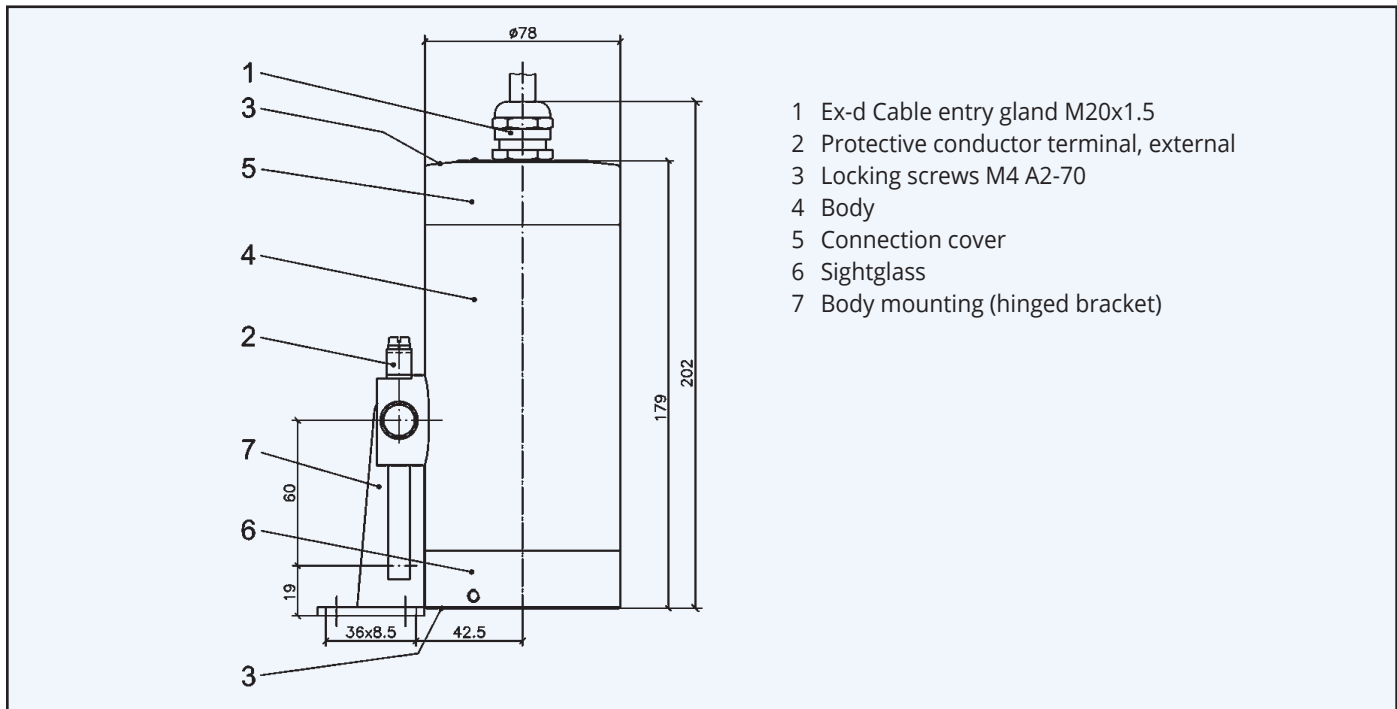

Mounting:

Similar to the internationally renowned Lumistar luminaires, the camera is secured to the cover flange of a circular sight glass fitting (to DIN 28120 or similar) using the hinged bracket included in the scope of supply (hinged bracket 1.4301). Alternatively, the special camera head can be mounted by way of a flanged adapter.

Illumination:

- If there is not sufficient natural light in the vessel, an appropriately dimensioned Lumistar luminaire can be additionally installed.
- A separate arrangement consisting of light glass and camera glass is a further option for consideration. This combination depends on the process and the reactor size as well as on the surface of the vessel, the medium in question, and the angle of incidence.
- Consistently uniform illumination should be ensured.

	VISULEX Camera K55-4K-E
MOD (Min. Object Distance)	0.3 m
Image sensor	1/2.5" 8.29 MP
Resolution max.	3840 X 2160 p
Light sensitivity	~ 0.05 Lux
Frame rate max.	30/25 fps
Video compression	H.264, H.265, (+), MJPEG
Focal length	8 mm (39°); 6 mm (54 °); 5.4 mm (60°)
Network protocol	TCP/IP, UDP, 1Pv4, 1Pv6, HTTP, HTTPS, FTP,RTP, UPNP,RTSP, RTCP, DHCP, OpenVPN
Power supply	PoE IEEE 802.3af
ONVIF	ONVIF ProfileS
Web Browser	MS Internet Explorer, Safari*, Mozilla*, Google Chrome*, Edge* (*Setup limited)

Order data:

e.g. VISULEX camera K55-4K-Ex, cable length 50 m, focal length 6mm (54°)

All dimensions in mm unless stated otherwise. Subject to change without prior notice.