

Circular Stainless Steel Sightglass Fittings Low Pressure Weld-Type

These sight glass fittings are designed for welding into or onto vessel walls, complete with a glass disc and relevant gaskets on each side bolted between circular flanges.

The advantages of these lightweight, low profile windows for low pressure vessels (compared to the standard 28120 design) are:

- smaller outer diameter, and therefore smaller vessel cutout
- shallower height above weld
- less weight
- easier to clean
- lower profile

Viewing Diameter: 80 to 225 mm (3" to 9" nominal)

Application:

For observation of interior of tanks, silos, mixers, dryers, separators, pipelines etc.

Operating Conditions:

Operating pressure: 15 psig

Operating temperature: max. 280° C with Borosilicate glass to DIN 7080

Combinations:

These sightglass units can be combined with Lumiglas luminaires for use in hazardous areas as well as under all normal working conditions (See Lumiglas Luminaire data sheets). The cover flanges can be drilled and tapped for luminaires.

Also available are sightglass wipers type SW I.

Certification/Standard

Material certifications available upon request.

Material of components:

(refer to adjoining exploded view)

Item	Part	Material options
1	Base flange (welding flange)	316L Stainless Steel (1.4535) or other
2	Gaskets	Non-Asbestos, Silicon, PTFE, or other
3	Sightglass disc	Tempered borosilicate glass or other
4	Cover flange	316Ti Stainless steel (1.4571) or other
5	Bolting	304 Stainless steel (A2) or other

Installation:

After welding in the base flange (1) into the vessel wall, gaskets (2), glass sightglass disc (3) and cover flange are carefully laid and bolted together with bolts (5). Tighten progressively on a diametric cross basis with hex wrench.



Complete assembly of circular stainless steel sightglass unit.

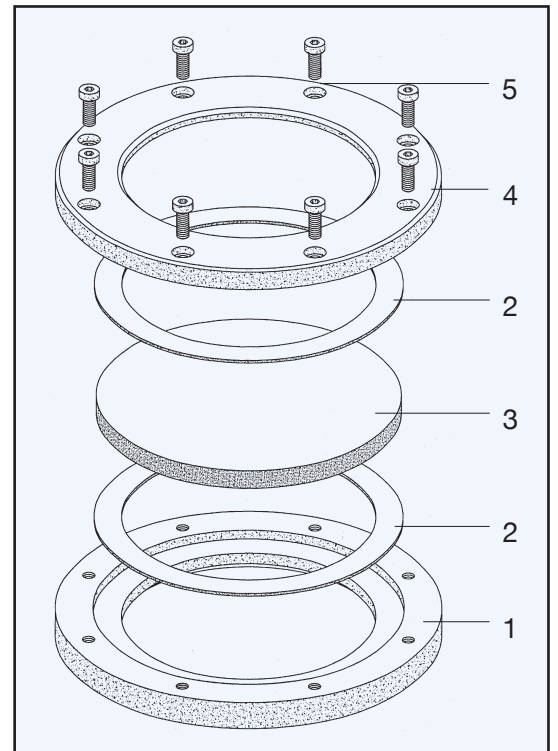

Exploded view of circular stainless steel sightglass unit.

Dimensions for lightweight stainless steel circular sightglass – viewing diameter to DIN 28120

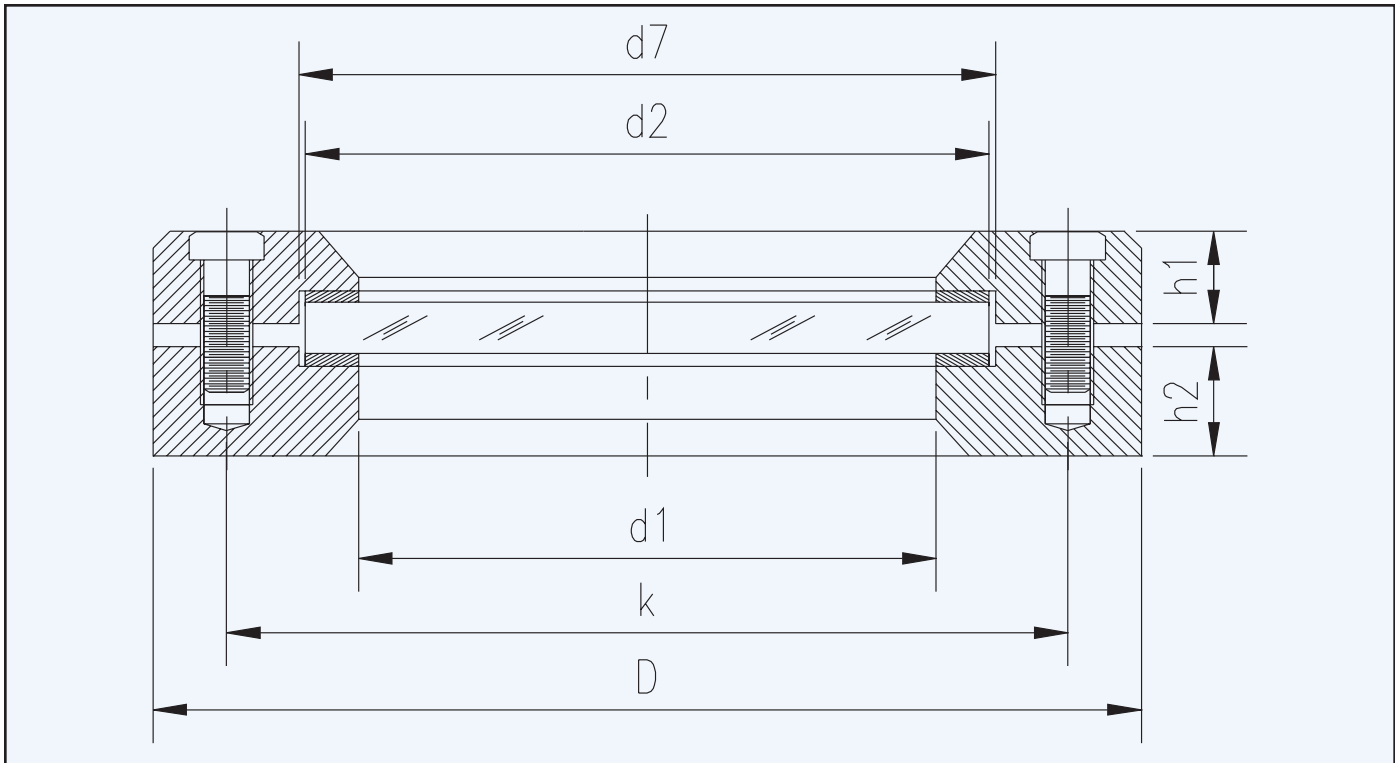

Size		DN50	DN80	DN100	DN125	DN150	DN200
Nominal bore	DN	50	80	100	125	150	200
Viewing diameter	$d1$	80 (3.15")	100 (3.94")	125 (4.92")	150 (5.91")	175 (6.89")	225 (8.86")
Sightglass disc	$d2$	100	125	150	175	200	250
	s	10	10	10	10	10	10
	D	140 (5.51")	165 (6.50")	190 (7.48")	215 (8.46")	240 (9.45")	290 (11.42")
	k	120	145	170	195	220	270
	$h1$	10	10	10	10	10	10
	$h2$	15 (0.59")	15 (0.59")	15 (0.59")	15 (0.59")	15 (0.59")	15 (0.59")
Securing bolts	No.	4	8	8	8	8	8
	Size	M6	M6	M6	M6	M6	M6
Gaskets	$d1$	80	100	125	150	175	225
	$d7$	102	127	152	177	202	252

Ordering Information:

please indicate Nominal bore size (DN)

Material: Base flange (optional conformity certificate) 3.1 A (TÜV)/3.1 B

Cover flange (optional conformity certificate) 3.1 A (TÜV)/3.1 B

Bolts

Sightglass disc

Gaskets

All dimensions in mm unless stated otherwise. Use mm dimensions for accuracy. Subject to change without prior notice.