



Rectangular Weld Pad Gage

Model RECTWP

Installation / Operation / Maintenance Manual

P.O. Box 1116
Twinsburg, OH 44087
Phone: 330/405-3040 • Fax: 330/405-3070
E-mail: view@ljstar.com • Web Site: www.ljstar.com

Table of Contents

1.00	Warranty	1
	1.10 Exceptions.....	1
	1.20 Provisions.....	1
2.00	Introduction	1
	2.10 Components	1
	2.20 Pressure / Temperature Specifications.....	2
3.00	Installation	4
	3.10 Unpacking.....	4
	3.20 Visual Inspection	4
	3.30 Positioning the Visual Flow Indicator	4
	3.40 Preparing the Rectangular Weld Pad Gage for Installation.....	4
	3.50 Welding.....	5
	3.60 Assembly of Rectangular Weld Pad Gage.....	6
4.00	Start Up	8
5.00	Maintenance	8
	5.10 Routine Maintenance Activities.....	8
	5.11 Sight Window	8
	5.12 Gaskets	9
	5.13 Corrosion.....	9
6.00	Disassembly / Reassembly	9
	6.10 Disassembly	9
	6.20 Reassembly	10
7.00	Telephone Assistance	10
8.00	Exploded Cross Section View	11

1.00 Warranty

L. J. Star warrants its Rectangular Weld Pad Gage against defects in material and workmanship for a period of eighteen months from the date of shipment. L. J. Star will, at its option, repair or replace those products that fail to perform as specified with the following exceptions. This warranty does not apply to glass breakage or any other liability other than materials and workmanship.

1.10 Exceptions

Products repaired or modified by persons not authorized by L. J. Star.

Products subject to misuse, negligence or accidents.

Products that are connected, installed or otherwise used in a manner not in accordance with the manufactures instructions.

1.20 Provisions

L. J. Star's responsibility hereunder is limited to repairing or replacing the product at its expense. L. J. Star shall not be liable for loss, damage or expense directly or indirectly related to the installation or use of its products, or from any other cause or for consequential damages. It is expressly understood that L. J. Star is not responsible for damage or injury caused to other products, building, property or persons by reason of the installation or use of its products.

This warranty is in lieu of any other warranty expressed or implied by any party other than L. J. Star. Repairs and/or replacements shall be at the sole discretion of L. J. Star based upon the terms and conditions.

2.00 Introduction

L. J. Star's Rectangular Weld Pad Gage [RECTWP] is designed to be welded to your process vessel. Visible glass sizes are 5/8" in width and range from 5-1/4" to 141-1/4" in length.

The sight window is secured in the RECTWP by compressing it between a cover flange and the weld pad base. The cover flange is then attached with threaded studs and nuts. When properly installed your RECTWP can provide a maximum design rating of 150 psig @ 500° F [gasket material dependent]. Both flat or radius weld pads are available.

2.10 Components

Each Rectangular Weld Pad Gage is comprised of six basic components. While various materials of construction are available, each complete unit must have these parts.

Weld Pad

The sight window mounting surface welded to the process vessel. It is also the base used to secure the studs.

Sealing Gasket

This is placed between the sight window and weld pad to seal the unit.

Sight Window

The material (transparent or reflex) allowing visual access to the process vessel.

Cushion Gasket

Placed between the sight window and cover flange to prevent damage to the sight window. The material used for the cushion gasket must be constructed from a harder material than the sealing gasket for proper compression.

Cover Flange

This provides a recessed surface for the cushion gasket and sight window. In conjunction with the studs/nuts it generates the compressive force on the sight window and gaskets.

Studs/Nuts

They are utilized to secure the sight window and cover flange through mechanically induced compression.

2.20 Pressure / Temperature Specifications

The allowable pressure / temperature limitations for your RECTWP assembly are material dependent. The combined effects of the weld pad and cover flange with the gasket material are displayed below.

DANGER

Do not exceed the listed design ratings. Failure to following these instructions could result in leaks, glass breakage or sudden escape of process fluid or pressure. Should this occur you risk severe personal injury and property damage.

Rectangular Weld Pad Gage Operating Pressure / Temperature

Body Material	Gasket Material	Pressure / Temperature Rating
Carbon Steel	EPDM	150 psig @ -20° F to 300° F
	TFE	150 psig @ -20° F to 450° F
	Viton®	150 psig @ -20° F to 400° F
	Silicone	150 psig @ -20° F to 450° F
316 STS	EPDM	150 psig @ -60° F to 300° F
	TFE	150 psig @ -40° F to 450° F
	Viton®	150 psig @ -20° F to 400° F
	Silicone	150 psig @ -75° F to 450° F

Table 1

3.00 Installation

3.10 Unpacking

Upon receipt of your RECTWP check all components carefully for damage incurred during shipment. If damage is discovered or suspected, do not attempt installation. Notify the carrier immediately and request a damage inspection.

Check each item against the enclosed packing list. Confirm that the attached identification tag lists the proper model and design rating for the intended application.

3.20 Visual Inspection

Insure your RECTWP is free of any damage due to mishandling or improper storage before proceeding with installation. Specific areas of concern are the sight window, weld pad and cover flange.

Examine the sight window for evidence of scratches, chips or cracks. If any are present, do not proceed with installation.

The weld pad and cover flange must be free of any foreign material. The presence of foreign material could result in point load stress as the sight window is secured. This in turn may lead to sight window failure.

3.30 Positioning the Rectangular Weld Pad Gage

Careful thought should be given to the location your RECTWP will occupy prior to installing it. Placing your unit in an area where it is subjected to excess mechanical or thermal stress will greatly reduce its serviceable life.

The following criteria should be used to determine the optimum location for your RECTWP.

- a) Is it protected from objects that may come in contact with the sight window? This includes environmental contaminants, tools and machinery.
- b) Will the RECTWP be protected from rapid temperature changes? You should avoid exposing it to cold air blasts or cold wash down water.

If you cannot provide a positive response to both questions, the location of your RECTWP should be reevaluated.

3.40 Preparing the Rectangular Weld Pad Gage for Installation

- a) Set your RECTWP with the weld pad face down on a stable work surface.
- b) Carefully remove the cover flange, sight window and gaskets. These components are safe to reuse during the installation process only. They were not torqued prior to being shipped.

- c) Insert a steel spacer in the recessed area of the weld pad. This substitutes for the sight window and gaskets during installation. The steel spacer is required to prevent warping the weld pad during installation. Use extreme care to guard against damage to the seating surface of the weld pad and cover flange.
- d) Replace the cover flange and torque in place (see section 3.60 for torque procedure).

DANGER

Avoid damage to your Rectangular Weld Pad Gage during disassembly. Harming any component could result in the sudden release of pressurized process fluid and cause personal injury and property damage.

3.50 Welding

Welding performed in conjunction with your Rectangular Weld Pad Gage should adhere to applicable national codes and recommended safety practices. Specific procedures utilized must be determined by and are the responsibility of the individual user.

WARNING

Welding should never take place while the vessel is operational. The Rectangular Weld Pad Gage must be relieved of pressure, allowed to reach ambient temperature and purged of all fluids. Failure to do so could result in personal injury or property damage.

Use the pad as a template and mark the vessel wall at the top and bottom of the slot with a pencil. Drill two holes in the vessel wall corresponding to the top and bottom of the slot in the weld pad. (Drill two holes for a single section pad, four holes for a two-section pad, etc.) Use a 1/2" to 5/8" drill. The holes are drilled in order to allow fluid to pass into the welding pad from the vessel. If transparent weld pads are to be used, the vessel wall should be slotted. You have three different choices regarding the relationship in size and position of the hole relative to your gage.

- a) Flat Vessel Wall with a Flat Weld Pad (Figure 1)

The slot must be equal to or slightly larger than the vision slot of the RECTWP. Center the weld pad of the gage over the opening.

Secure the weld pad in place. Utilize good welding practices to prevent distortion of the weld pad.

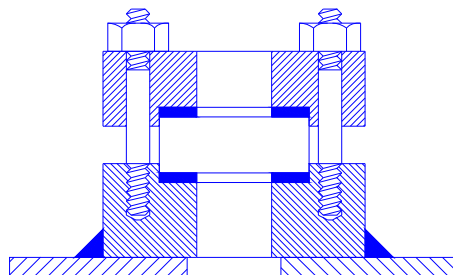

Figure 1

b) Radius Vessel Wall with Flat Weld Pad (Figure 2)

The slot must be equal in size and shape to the outside dimensions of the weld pad. This will allow the weld pad to be inserted into the vessel.

Part of the weld pad should extend into the vessel. Two weld beads can now be applied. One between the outside vessel wall and the weld pad. The second between the inside wall and the weld pad. Utilize good welding practices to prevent distortion of the weld pad.

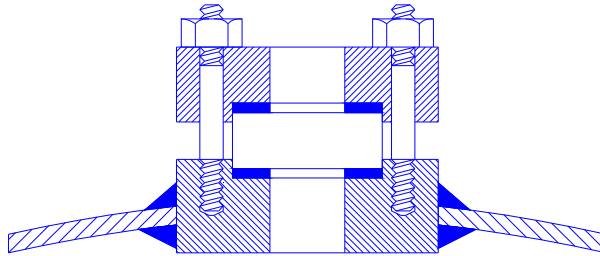

Figure 2

c) Radius Vessel Wall with Radius Weld Pad (Figure 3)

The slot must be equal in size and shape to the outside dimension of the weld pad. This will allow the weld pad to be inserted into the slot. Affix the weld pad using good welding standards to prevent distortion of the pad.

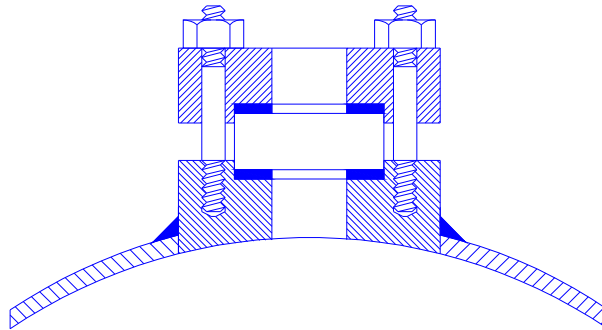

Figure 3

3.60 Assembly of Rectangular Weld Pad Gage

Proceed with the following steps only after the weld pad has returned to ambient temperature.

- a) Remove the cover flange and steel spacer from the weld pad.
- b) Check the recessed face of the cover flange and weld pad for foreign material. If any exists, clean the surface.
- c) Carefully place the sealing gasket in the recessed area of the weld pad.

- d) Clean and install the sight window in the recessed area of the weld pad.
- e) Place the cushion gasket on the top of the sight window.
- f) Align the holes in the cover flange with the studs in the weld pad. Carefully lower the cover flange on to the cushion gasket. Insure the cushion gasket and sight window are properly seated in the cover flange recess.
- g) Place the nuts on the studs and tighten with fingers.
- h) Use a torque wrench to complete the tightening procedure. Follow the proper sequence as demonstrated in Figure 4. The correct torque value for the gasket material utilized can be found in Table 2. The nuts should be tightened in increments of 3 ft-lbs.

Torque Sequence

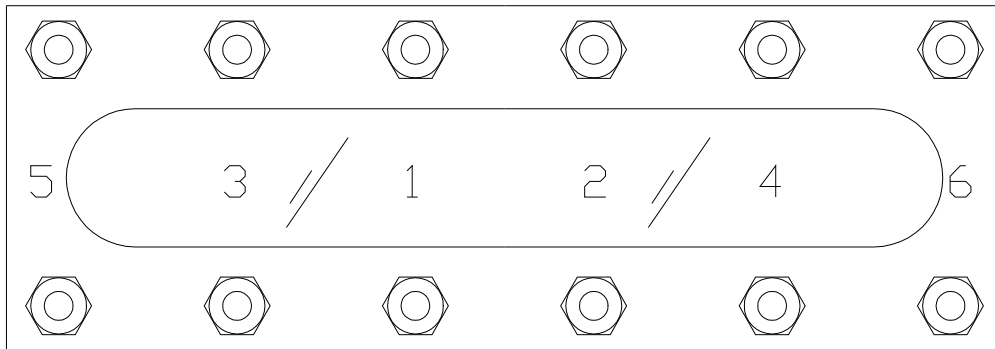

Torque Values (ft-lbs) [Based Upon Seal Gasket Material]				
Model	EPDM	Viton®	Silicone	TFE/Gylon
Rectangular Weld Pad Gage (Reflex or Transparent)		6-8		10-15

Table 2

WARNING

Do not torque the nuts of your Rectangular Weld Pad Gage while it is under pressure. It will result in incorrect torque values and increase the likelihood of sight window breakage. Before torquing the RECTWP it must be free of pressure, allowed to reach ambient temperature and drained of all fluids. Failure to do so could result in personal injury and property damage.

4.00 Start Up

Prior to placing your RECTWP into operation, insure all installation procedures have been completed. Verify the proper torque sequence and values have been applied. Check the sight window for any damage that may have occurred during installation.

Bring the RECTWP into service slowly. Rapid pressurization or temperature change will subject the sight window to shock that could significantly shorten its service life or result in failure.

5.00 Maintenance

Periodic maintenance and inspection of your RECTWP is recommended to insure the unit is in proper working order. The frequency of maintenance will vary with the application. The end user must determine the appropriate maintenance schedule based upon their experience with the specific application. Realistic maintenance schedules can only be determined with full knowledge of the service and application involved.

WARNING

Do not proceed with any maintenance if the Rectangular Weld Pad Gage is still at operating pressure or temperature. Relieve the unit of pressure, allow it to reach ambient temperature and purge it of all fluids. Failure to do so could result in personal injury or property damage.

Any established maintenance procedure should include the following activities.

Check:

- A) the sight window for signs of damage or wear.
- B) the RECTWP for signs of leaks at gaskets or welds.
- C) the RECTWP for signs of internal or external corrosion.
- D) bolt torque values.

5.10 Routine Maintenance Activities

WARNING

The use of personal safety apparatus when viewing the process fluid or during maintenance is highly recommended. This includes but is not limited to eye and skin protection. Failure to do so could result in personal injury.

5.11 Sight Window

The sight window should be carefully and regularly inspected. Examine it for evidence of scratches, clouding, etching or any other physical damage. A damaged sight window has been weakened and is susceptible to breaking. Using a concentrated light at a 45° angle to the surface of the sight window will help detect any of these conditions. Damaged areas will glisten more brightly than the surrounding surface.

Clean the surface of your sight window. This can be accomplished by using standard commercial glass cleaner and a soft cloth. Never use an abrasive material, wire brush or scraper.

If damage to the sight window is detected your Rectangular Weld Pad Gage should be taken out of service immediately. Do not continue with normal operation until the sight window has been replaced.

5.12 Gaskets

Regularly check your RECTWP for evidence of leaks at the gasket surface. If leaks are detected remove the unit from service immediately. Once the gage has reached ambient pressure and temperature verify the torque value on the nuts. If the torque is correct, replace the gaskets.

5.13 Corrosion

Evidence of either internal or external corrosion is an indication that the proper material of construction may not have been chosen for your application. The end user is responsible for determining the material that is compatible with both the process fluid and the surrounding environment. If corrosion is detected the RECTWP should be removed from service and the material compatibility investigated by the end user.

6.00 Disassembly / Reassembly

DANGER

Do not attempt to disassemble your Rectangular Weld Pad Gage while it is still in operation. Pressure increases the possibility of the sight window breaking and process fluid escaping. The unit must be relieved of pressure, allowed to reach ambient temperature and purged of all fluids prior to proceeding. Failure to do so could result in personal injury and property damage.

6.10 Disassembly

The first step in the disassembly of your Rectangular Weld Pad Gage is to remove the nuts from the studs. The same pattern used to torque the nuts should be followed to remove them. Once this is complete, take off the cover flange, cushion gasket, sight window and sealing gasket using appropriate safety precautions.

The used sight window and gaskets should be disposed of immediately. They may contain hidden damage and pose a safety risk. Never attempt to reuse these components once they have been in service.

DANGER

Never attempt to reuse sight windows or gaskets that have been placed in service. Hidden damage or stress will greatly increase the possibility of the sight window breaking and process fluid escaping. Failure to follow this procedure could result in personal injury and property damage.

6.20 Reassembly

Clean the gasket seating surface of the weld pad and cover flange before proceeding with reassembly. This can be accomplished by using a soft metal scraper. Use extreme care to avoid damaging the seating surface. Failure to properly prepare the surface will result in leaks and sight window breakage.

Check the flatness of both seating surfaces. They must be within 0.005 inches (0.13 mm) T.I.R. If the seating surfaces do not fall within this tolerance and cannot be corrected, the gage must be replaced.

Follow the procedures outlined in section 3.60

Before finishing your reassembly complete the inspection process outlined in section 3.20. If any signs of damage exist, replace that component before proceeding. The same assembly procedures identified in section 3.60 should be utilized.

7.00 Telephone Assistance

For assistance with your L. J. Star Rectangular Weld Pad Gage contact your local representative or the factory. In order to answer your questions quickly and completely please have the following information available.

- Model Number
- Serial Number
- Date the unit was placed in service
- Process media
- Operating pressure
- Operating temperature
- Brief description of problem(s)

8.00 Exploded Cross Section View

