



Hygienic Bubble Trap

Installation and Operations Manual

Darren Bean / J. LaFleur
1/1/2010

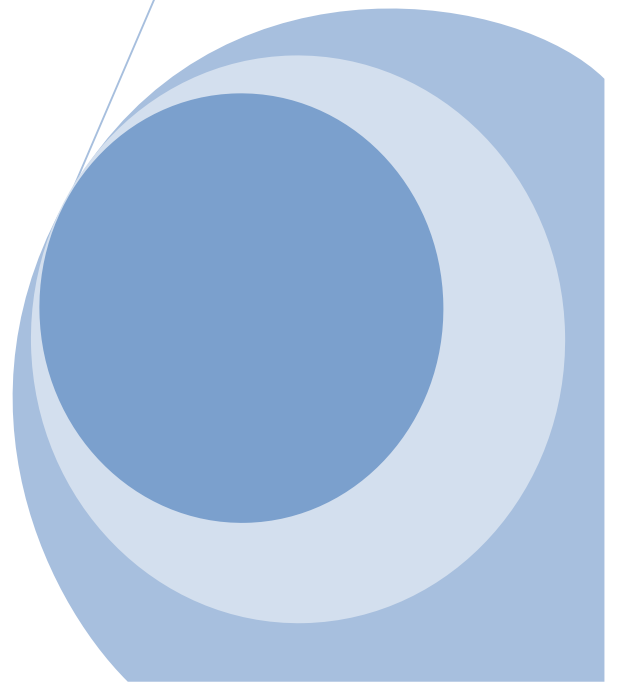
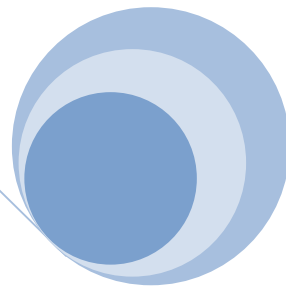
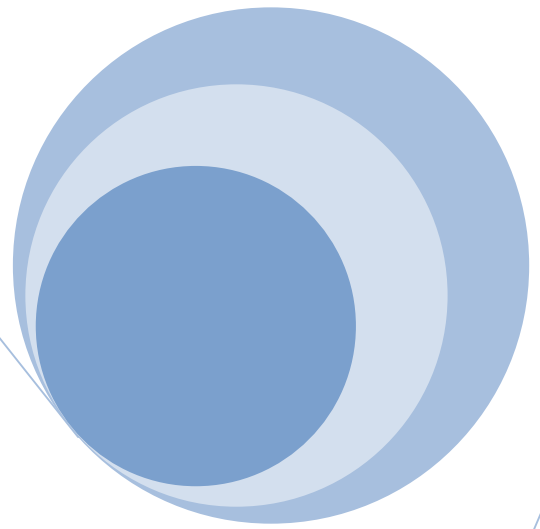

Table of Contents

1.00	Warranty	1
	1.10 Exceptions.....	1
	1.20 Provisions.....	1
2.00	Components	1
	2.10 Exploded Views.....	2
3.00	Pressure / Temperature Specifications	3
4.00	Receiving	3
	4.10 Unpacking.....	3
	4.20 Visual Inspection	3
5.00	Gasket/Cylinder Replacement	4
6.00	Maintenance	6
7.00	Telephone Assistance	7

1.00 Warranty

L. J. Star warrants its Hygienic Bubble Trap against defects in material and workmanship for a period of eighteen months from the date of shipment. L. J. Star will, at its option, repair or replace those products that fail to perform as specified with the following exceptions. This warranty does not apply to glass breakage or any other liability other than materials and workmanship.

1.10 Exceptions

Products repaired or modified by persons not authorized by L. J. Star.

Products subject to misuse, negligence, or accidents.

Products that are connected, installed, or otherwise used in a manner not in accordance with the manufactures instructions.

1.20 Provisions

L. J. Star's responsibility hereunder is limited to repairing or replacing the product at its expense. L. J. Star shall not be liable for loss, damage or expense directly or indirectly related to the installation or use of its products, or from any other cause or for consequential damages. It is expressly understood that L. J. Star is not responsible for damage or injury caused to other products, building, property or persons by reason of the installation or use of its products.

This warranty is in lieu of any other warranty expressed or implied by any party other than L.J. Star. Repairs and/or replacements shall be at the sole discretion of L. J. Star based upon the terms and conditions.

2.00 Components

Each Hygienic Bubble Trap is comprised of eight components. Depending upon the Bubble Trap utilized your dimensions of components will vary.

Lid Assembly

The top of the bubble trap which includes your vent connection as well as any additional connections requested.

Base Assembly

The bottom of the Bubble Trap which incorporates the inlet and outlet connections.

Cylinder

The transparent material allowing visual access to the process fluid.

Sealing O-Ring

The elastomeric material located between the top and bottom of the Cylinder. The o-rings complete the sealing of the cylinder to the Lid and Base of the unit.

Cushion O-Ring

The elastomeric material located between the outer wall of the Cylinder and the inner wall of the Lid and Base. The o-rings help to locate the Cylinder properly and to protect the Cylinder from coming into contact with metal.

Tie Rods

Metallic rods designed to connect the Lid and Base together. The Tie Rods provide the means to ensure structural integrity of the trap upon assembly completion.

Spring Washers

Metallic parts which are located between the Base and Nuts as well as between the underside of the lid and the top of the tie rods. The spring washers assist in ensuring compression to seal the unit and prevent leaks.

Nuts

Metallic parts which secure the Tie Rods to the Base and provide the proper compression to seal the unit and prevent leaks.

2.10 Exploded Views

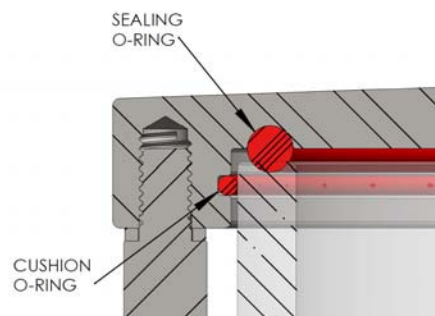
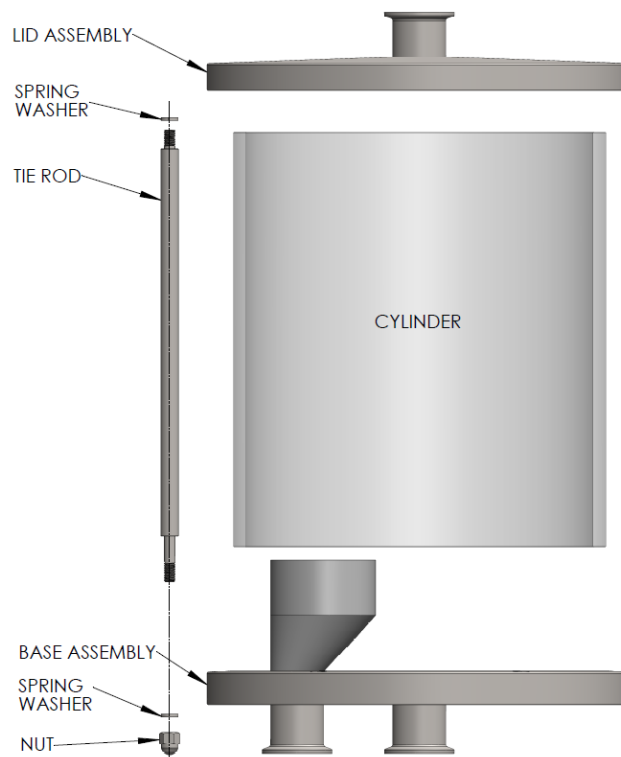

3.00 Pressure / Temperature Specifications

The allowable pressure / temperature limitations for your Hygienic Bubble Trap are material dependent. The combined effects of the Size, Seal Material, and Cylinder material will determine the capability of the unit. Please consult the associated Data Sheet or Part Description for allowable pressure and temperature environments.

DANGER

Do not exceed the design ratings. Operating beyond these limits could result in leaks, glass breakage or sudden escape of process fluid or pressure. Should this occur you risk severe personal injury and property damage.

4.00 Receiving

4.10 Unpacking

Upon receipt of your Hygienic Bubble Trap, check all components carefully for damage incurred during shipment. If damage is discovered or suspected, do not attempt installation. Notify the carrier immediately and request a damage inspection.

Check each item against the enclosed packing list. Confirm that the attached packing list and part markings list the proper model and design rating for the intended application.

4.20 Visual Inspection

Ensure your Hygienic Bubble Trap is free of any damage due to mishandling or improper storage before proceeding with installation. Specific areas of concern are the Cylinder and connections.

Examine the Cylinder for evidence of scratches, chips or cracks. If any are present, do not proceed with installation. Surface abrasions weaken the window and it will not be able to support the listed design rating. Please contact the factory for consultation.

The connections must be free of any foreign material. The presence of foreign material may prevent the unit from sealing.

5.00 Gasket/Cylinder Replacement

Firstly, turn the unit upside down, sit the unit on a suitable surface, to ensure any lid fittings are protected from damage.
Next, remove the nuts and washers from the underside of the unit.

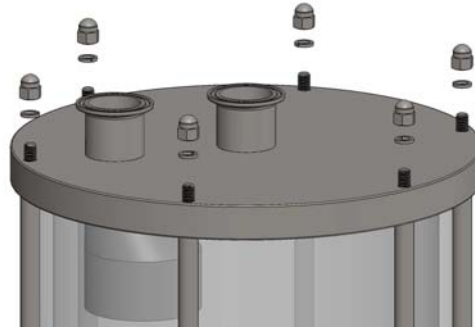

Then, carefully lift the base from the unit, ensuring it is lifted evenly to avoid damage to either cylinder, gaskets or tie rods.

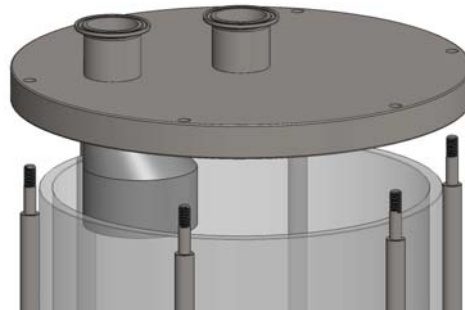

Now, lift the cylinder carefully from the unit. It may be quite tight, if this is the case, sitting the unit in hot water may aid the removal of the glass as it will soften the gaskets, making them more pliable.

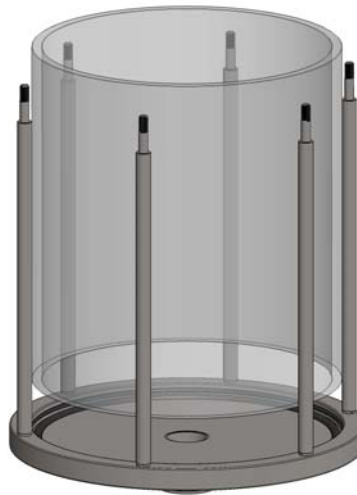

Remove all the gaskets. Fit a new cushion gasket within the base unit and also new cushion and face gaskets in the lid unit (shown in red and in section for clarity)



Base Unit

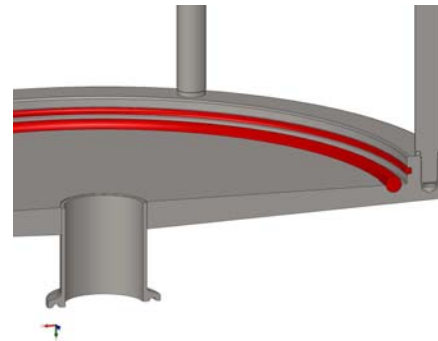

Lid Unit

Refit the glass into the lid unit ; if the glass is too tight, run a small bead of (FDA Compliant) silicone lubricant against the cushion gasket to aid fitting. With the glass fitted into the lid unit, sit the remaining face seal ontop of the glass, as shown in the second image below.

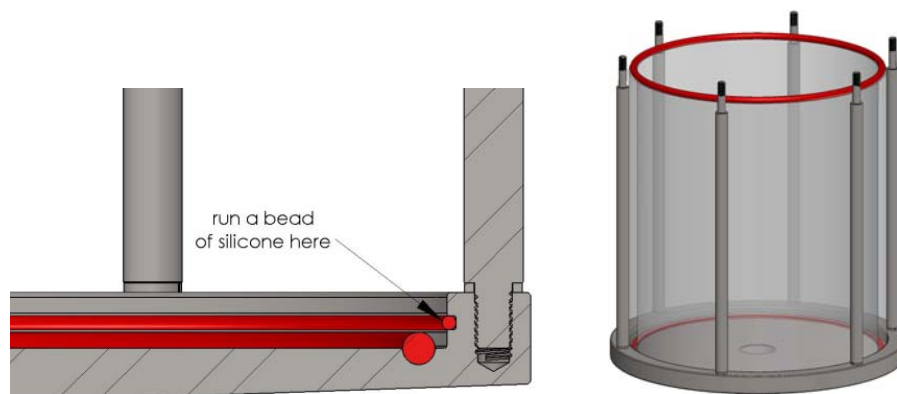

Now refit the base section, it may be necessary to apply a bead of silicone to the cushion gasket again. The face seal should be accommodated into the mating groove within the base section. If the face seal moves during assembly, and is subsequently not located correctly, the operation will need to be repeated again.

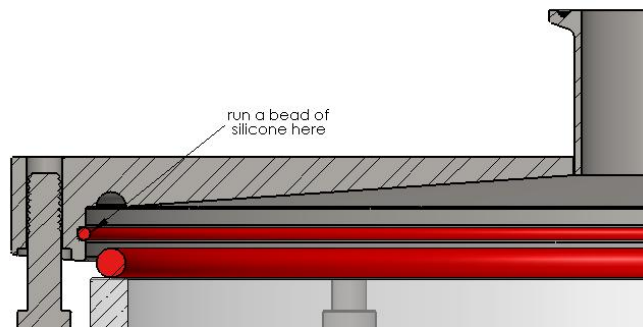

Once the base section is in place and the face seal is seated correctly, refit the nuts and washers. The nuts should be tightened equally around the diameter until they have “bottomed out”. Once metal to metal is achieved, the gaskets will be in correct compression.

Finally, turn the unit back over, to its correct orientation and visually check gaskets to ensure all are seated correctly; if they are not, the operation will need to be repeated.

6.00 Maintenance

Periodic maintenance and inspection of your Hygienic Bubble Trap is recommended to ensure the unit is in proper working order. The frequency of maintenance will vary with the application.

The end user must determine the appropriate maintenance schedule based upon their experience with the specific application. Realistic maintenance schedules can only be determined with full knowledge of the service and application involved.

WARNING

Do not proceed with any maintenance if the Hygienic Bubble Trap is still at operating pressure or temperature. Relieve the unit of pressure, allow it to reach ambient temperature and purge it of all fluids. Failure to do so could result in personal injury or property damage.

DANGER

Never attempt to reuse windows or gaskets that have been placed in service. Hidden damage or stress will greatly increase the possibility of the window breaking and process fluid escaping. Failure to follow this procedure could result in personal injury and property damage.

7.00 Telephone Assistance

For assistance with your Hygienic Bubble Trap contact your local representative or the factory. In order to answer your questions quickly and completely please have the following information available.

L.J. Star Inc. (330) 405-3040

- Part Number
- Supplier's name if not purchased direct from L. J. Star inc.
- Date the unit was placed in service
- Process media
- Operating pressure
- Operating temperature
- Brief description of problem(s)