

Installation and Operating Instructions **CE**

0093.060.00 b

Lumiglas luminaire USL 05

Important note:

Sight glass luminaires are specifically and solely designed for mounting on top or side of sight glass units. Never use a luminaire in place of cover flange or complete sight glass unit to provide a closure for an opening in a process vessel.

Operating conditions – general:

- Independent of vessel internal pressure/vacuum
- Max. permissible ambient temperature at cable entry gland 80°C.
Where ambient temperatures exceed 40°C heat resistant cable such as Sinotherm 110 H05GG-F 3G 1.5 mm², must be used.
- Protection Index: dust and waterjet proof, IP 65 to EN 60529/DIN VDE 0470 part 1

Electrical data – general:

- Voltage, power and protection are shown on the identity plate
- The version with built in transformer is PTC protected; fuse change becomes unnecessary!
- Supply: AC or DC depending on luminaire make up
Caution: Luminaires with integral transformer only AC may be used.
- **Caution:** Excessive voltage will shorten lamp life!

Electrical connection:

- The cable entry gland is designed only for use with cables which are not armoured. The cable sheath is sealed by the cable entry gland.
- Select a cable suitable for the operating conditions and the cable outside diameter should match the cable entry gland (2) – M20x1.5
- Loosen and unscrew lens ring (1) with claw spanner
- Loosen cable gland (2)
- Pass cable through cable entry gland (2) and fasten cores onto terminals in luminaire body (4)
- Tighten cable gland (2)
- Refit lens ring (1) and screw tight until seal is made
Caution: ensure O-ring gasket lies correctly in its recess in luminaire body.

Lamp change:

- Disconnect power
- Unscrew lens ring (1) with claw spanner (to be ordered separately)
- Pull out defective lamp (2 pin)
- Holding new lamp (use only recommended parts) with protective material, carefully insert into two pins in socket and gently but firmly push home until correctly seated
- Screw lens ring (1) back in until fully sealed (O-ring squeezed)
- **Caution:** Ensure O-ring gasket lies correctly in its recess in luminaire body
- Reconnect power

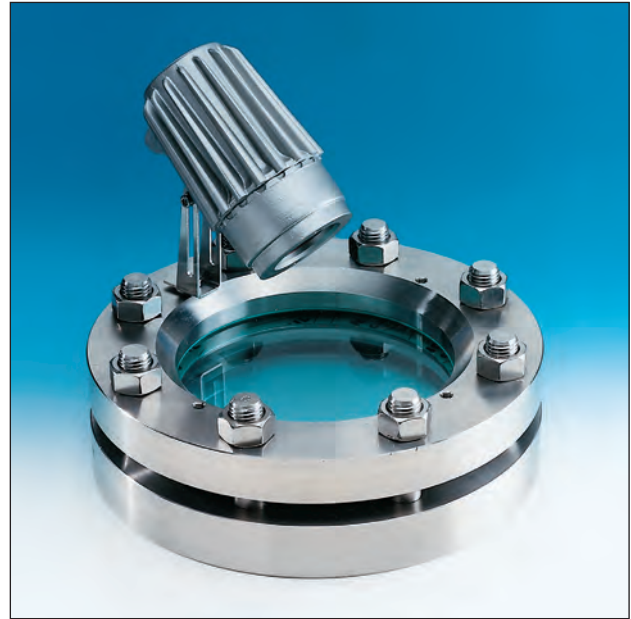

Application as combined sight and light port on a sight glass fitting acc. to DIN 28120, mounting by way of hinged bracket.

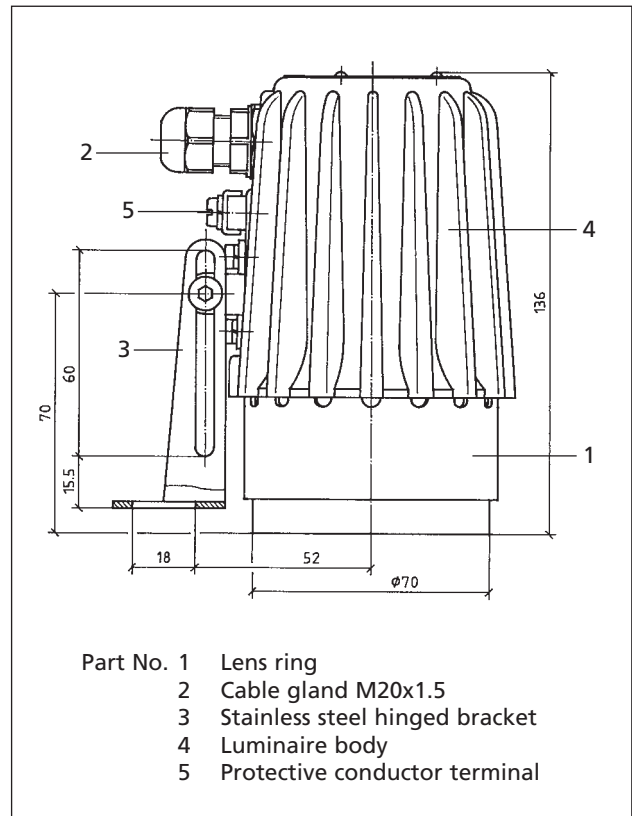

• **Mechanical installation:**

Caution: Do not look into light – danger of impaired eyesight! Before commencing installation please refer to the information sheet 'Important guidelines for use of sight-glass fittings...'

Where the luminaire is to be fitted to circular sight glasses or flow indicators, fastening is by means of the hinged securing bracket onto the cover flange. In the case of screwed sight-glass unit the luminaire is fastened to the slotted cover nut.

• **The Lumiglas luminaire USL 05 is suitable for sight glasses in the following nominal sizes, using the appropriate mounting:**

Type of fitting	from DN	Hinged bracket	Flanged adapter collar
Circular sight glass fitting			
DIN 28120	25	+	–
DIN 28121	40	+	–
Visual flow indicator	50	+	–
Screw-type sight glass fitting similar to DIN 11851	65	+	+
	80	+	+
	100	+	–
	125	+	–
	150	+	–

• **Mounting by way of hinged bracket:**

The hinged bracket is used to secure the luminaire to the cover flange of a circular sight glass fitting (also suitable for visual flow indicators). Alternatively, it can be attached to the slotted cover nut of screw-type sight glass fittings to DIN 11851.

The hinged bracket is fixed in place by turning the supplied M6 bolt into a blind hole which has previously been tapped in the pitch circle of the cover flange face. An additional option is to weld on the bracket.

• **Mounting by way of flanged adapter collar:**

The flanged collar is laid between the slotted cover nut (DIN 11851) and glass disc:

- unscrew slotted cover nut
- Fit a suitable gasket between glass and collar
- Insert adapter collar
- Retighten cover nut
- Slide luminaire body into adapter collar
- Tighten luminaire by radially located grub screw

• **Please note:**

Fastening and mounting elements, claw spanner, etc. should be ordered separately if needed.

• **Replacement parts:**

Screw-type lens (light aperture) with reflector, 5 W	1774.048.00
Screw-type lens (light aperture) with reflector, 50 W	1774.046.00
Screw-type lens (light aperture) without reflector, 20 W	1774.049.00
O-ring seal (Viton)	0862.036.00
Transformer prim. 240 V, sek. 10.5 V	0811.023.00
Transformer prim. 120 V, sek. 10.5 V	0811.024.00
Lamp socket, G4 (2-Stift)	1202.011.00
Lamp socket, GY6.35 (2-Stift)	1202.012.00
Mini-Spot Halogen reflector lamp 12 V/5 W	3232.221.00
Mini-Spot Halogen reflector lamp 24 V/20 W	3232.222.00
Halogen filament lamp 24 V/50 W	3232.242.00
• Accessories:	
Claw spanner	6816.001.00
Hinged bracket	0354.014.00
Flanged adapter collar	1356.010.00

• **Servicing:**

- Keep luminaire clean.
- Before closing the luminaire, re-lubricate the thread of the screw lens (e. g. with AEMA-SOL 6 from A.E. Matthes).
- Keep note of average lamp life.
- Use only original replacement parts.