

**HYGIENIC
CLAMPS**
ASME VIII PRESSURE VESSEL

Material	316 / 1.4401
Application	Pressure Vessel
Hinge Lay-Out	Hinge Plate & Safety Bolt

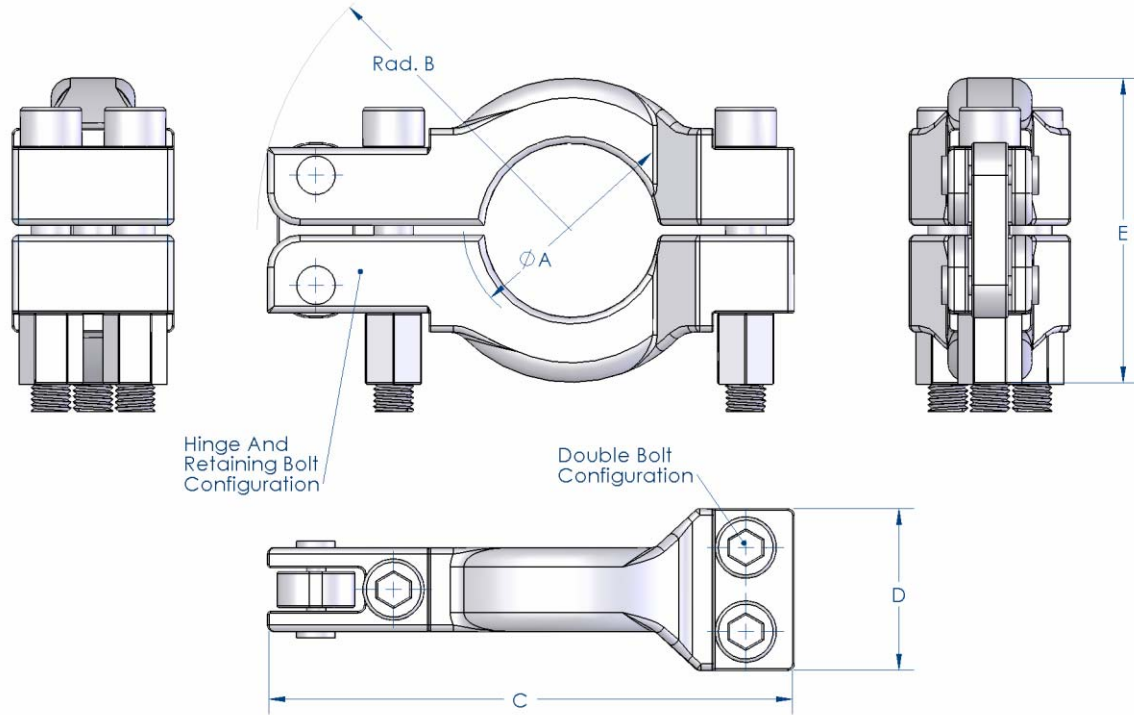

ASME VIII CLAMPS							
Nominal Clamp Sized	Dimensions (mm)					Mass (Kg)	Ordering Codes ASME VIII
	Flange ØA	Rad B	Length C	Length D	Length E		
1" - 1 1/2"	50.5	85.0	145.0	50.0	80.0	1.80	C010.6.ASME
2"	64.0	97.0	163.0	50.0	94.0	1.96	C020.6.ASME
3"	91.0	115.0	203.0	50.0	124.0	3.20	C030.6.ASME
4"	119.0	135.0	233.0	50.0	160.0	3.68	C040.6.ASME
6"	167.0	160.0	281.0	50.0	206.0	4.70	C060.6.ASME
6 5/8"	183.0	170.0	300.0	50.0	222.0	4.98	C066.6.ASME
8"	217.0	185.0	333.0	50.0	258.0	5.45	C080.6.ASME
10"	268.0	210.0	385.0	50.0	308.0	6.30	C100.6.ASME
12"	319.0	235.0	433.0	50.0	358.0	7.02	C120.6.ASME

L.J. STAR INCORPORATED
P.O. Box 1116 * Twinsburg, OH 44087
Tel: 330/405-3040 | Fax: 330/405-3070
e-mail: view@ljstar.com
website: www.ljstar.com

