

**Lumiglas Ex Fiber Optic Luminaire Type Lumiflex™ (Model USL08 LF-EX)
Conforms to UL 1598 & 844 Listed Class I, Div 1 & 2, Groups C & D**

ISO 9001
DATA SHEET 02-0265 10/14

- For mounting on sightglass fittings or for localized illumination of process operations in reactors, vessels and pipelines and where there is limited space, primarily in Ex hazardous zones.
- The unit is comprised of a general purpose sightglass luminaire modified to provide a fiber optic system, particularly suitable for use on processes in Class I, Division 1 & 2, Groups C & D which require a light.
- The unit can be installed for light and sight combination as well as with Lumiglas Ex-camera technology.

The Lumiflex Luminaire, specially developed for light guide duties, is characterized by its:

- Extremely high light output for a mere 39 W power low energy consumption
- Servicing intervals: filament lamp life greater than 6,000 hrs

Application:

- For the illumination of process operations and/or the internals of vessels and plant in Hazardous Locations designated Class I, Div 1 & 2, Groups C & D, where available space is limited.
- Light source can also be mounted away from vibrating vessel to extend bulb life.

Protection:

- Suitable for Wet Locations to UL-1598 & CSA C22.2 No. 250.0-08

Operating conditions:

- Independent of vessel internal pressure/vacuum
- Lumiglas Lumiflex approved for use in ambient temperatures up to 60°C.

Certified to:

- CSA C22.2 No. 250 & CSA C22.2 No. 137

Protection:

- Luminaires for Use in Hazardous (Classified) Locations (UL 844)
- Electric Luminaires for Use in Hazardous Locations (CSA C22.2 No. 137-M1981)

Explosion Groups: C & D

Temperature Class:

- T5 @ -20°C to +40°C
- T4 @ -20°C to +60°C

Electrical data and parts:

- In accordance with type test certification

Power supply: 120VAC

Operating voltages:

- Includes integral transformer: Primary voltage 120VAC, secondary voltage 10V (10V/39W lamp)

Easy electrical connections:

- Using integral terminal box; ½" NPT Connections (3 positions)
- Connections to be in accordance with National Electric Code® Requirements



Lumiglas Ex Fiber Optic Luminaire 'Lumiflex' shown mounted on a DIN 28120 sightglass fitting combined with high pressure Lumiglas wiper unit (Type II)



Lumiglas Fiber Optic Luminaire 'Lumiflex' on a 4" MetaClamp® Fused Safety Sight Window

Electrical connecting data for Lumiglas Ex Fiber Optic Luminaire Type Lumiflex USL08 LF-EX:

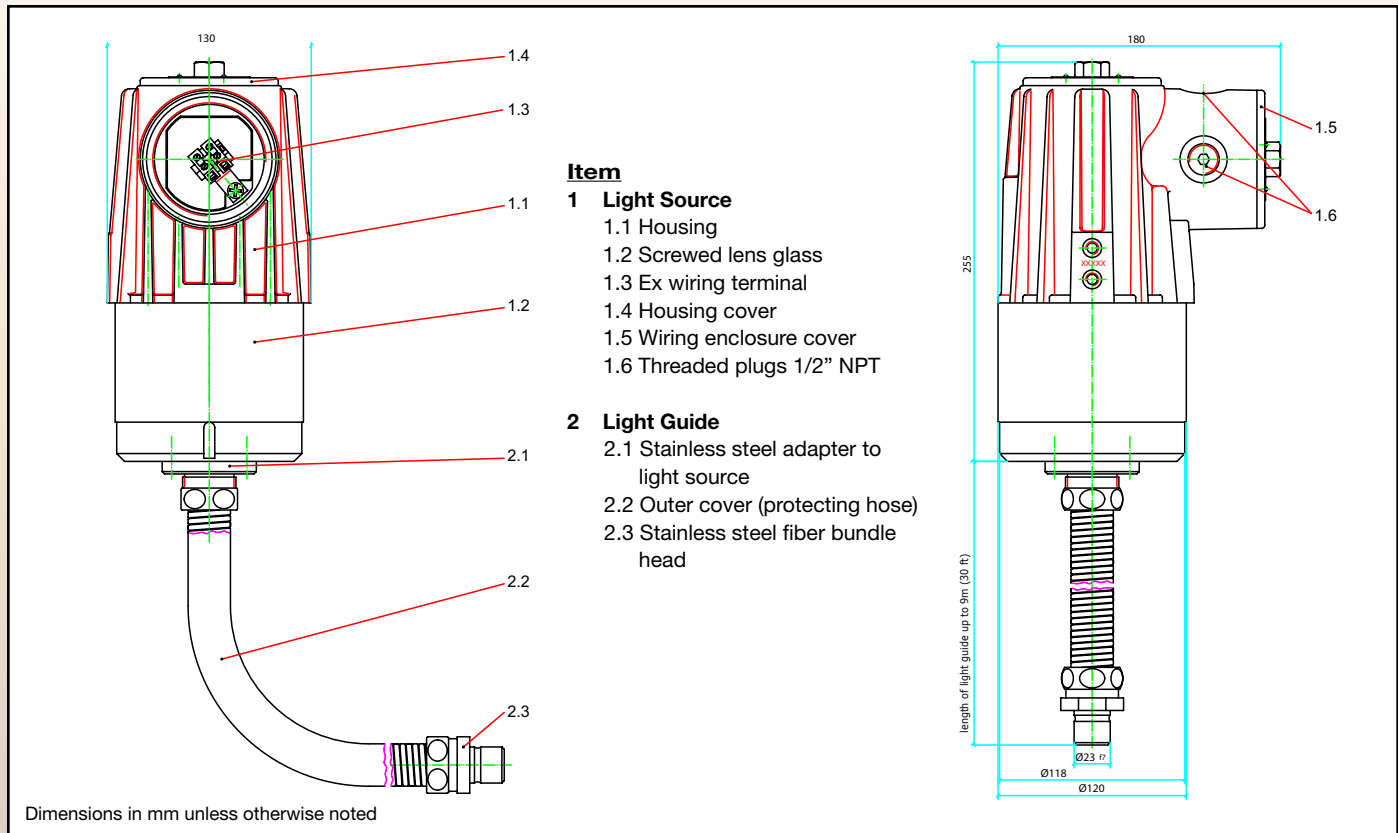

Parts, Construction and Materials:

- Luminaire body: Corrosion resistant aluminum alloy casting GKAlSi10Mg
- Light exit: Aluminum/glass unit; O-ring seal
- Mounting: Light source two part mounting bracket (included) GAlSi10Mg (PN: BRK EX08 S)
- Fiber bundle: (please indicate required length) includes stainless steel adapter to light source. Bundle sheathing is made of a flexible stainless steel hose or can be provided with an optional chemical resistant PVC casing. Bundle length available up to 30 ft.
- Weight: approximately 10 lbs. (excl. light guide)

Electrical connecting data for Lumiglas Ex light guide luminaire Lumiflex USL08 LF-EX:

- Model USL08 LF-EX
- Power Requirement: 120 Volt AC
- Integral Transformer: 120 VAC Primary, 10 Volt Secondary
- Halogen Filament Lamp: 10V/39W (Part No: BLB-L39-GYN)
- Temperature Class at maximum ambient temperature: T5 @ 40°C, T4 @ 60°C

Ordering information:

e.g. Lumiglas Ex light guide luminaire 'Lumiflex' USL08 LF-EX, 120/10V, 39 W, with straight mount brackets, with light guide length 36 inches, Part No. 08LF-1B1N36A.

Simplified mechanical mounting with specially designed brackets:

Using the specially designed mounting bracket the light source is mounted at a suitable point on the reactor or other area of plant in such a way that the fiber bundle is suspended free of tensile or torsional stress with a minimum bending radius of not less than 4", e.g. mounted on a sightglass fitting or other required location.

Accessories:

- Spanner Wrench for screwed lens ring for opening light housing (PN: L1106)
- Light guides are available in varying lengths up to 30 ft. (360 in.) Please indicate required length.
- Ex time delay push button switch unit, externally mounted for timed illuminating periods (see data sheet 02-0270).

Warning:

Light should not be operated in hazardous location without fiber bundle securely attached.



ISO 9001 QA CERTIFICATE
GERMAN MANUFACTURER:
F.H. PAPPENMEIER AWARDED QA APPROVAL CERTIFICATE