

Lumiglas Luminaire Stainless Steel ESL 25-Ex

II 2G Ex d IIC T4/T6
II 2D Ex tD A21 IP67 T130/T80°C

ISO 9001
DATA SHEET 02-0210 03/11

For mounting on sight glass fittings

Designed for universal applications, the Ex-type sight glass luminaire has been developed for use in potentially explosive environments. It is ideal for combined sight glass and light assemblies, either as a single-port version or with two separate ports.

Compact yet powerful:

Glare-free illumination; for use with circular sight glass fittings to DIN 28120, Bolt-On, Weld-Neck sight glass units to DIN 11851 (MV), and visual flow indicators.

Large light aperture and convenient lamp replacement thanks to optimized screw-in lens design.

Applications:

For illuminating visual flow indicators, pipelines, laboratory mixers, bioreactors as well as the interior of pressure vessels, tanks, agitators and other - normally closed - processing vessels in potentially explosive environments.

Gas: Zones 1 & 2; **Dust:** Zones 21 and 22.

Particularly suitable for use in sterile environments.

Protection: IP 65 and IP 67 per DIN EN 60529

Operating Conditions:

Independent of the internal pressure/vacuum in vessel. Under no circumstances should a sight glass luminaire be used to replace the cover flange or the sight glass/luminaire assembly or on its own to seal a vessel port.

Lumiglas luminaires of this series are approved for use in ambient temperatures of up to 60°C, depending on the lamp bulb fitted.

Technical data Ex protection:

This luminaire meets the essential safety and health requirements by complying with the regulations for

a) Gas

- EN 60079-0: 2006 General Requirements
- EN 60079-1: 2007 Flame-proof Enclosures
- Explosion group: IIC (includes II A and II B)
- Temperature class: up to T6 (depending on wattage)

a) Dust

- EN 61241-0: 2006 General Requirements
- EN 61241-1: 2004 Protection by Enclosures
- Temperature class: T130/T80°C (depending on wattage)

EC type-examination certification: BVS 08 ATEX E 137

II 2G Ex d IIC T4/T6
II 2D Ex tD A21 IP67 T130/T80°C

Voltage type: AC/DC, depending on lamp

Operating voltage:

Without integral transformer:

- 12 V... Halogen lamp 5 W, 10 W, 20 W
- 24 V... Halogen lamp 20 W

With integral transformer:

- 230 V... Halogen lamp 12 V/5 W/10 W
- 120 V... Halogen lamp 12 V/5 W/10 W
- 5 W = PTC protection, 10 W = thermal fuse

Straightforward electrical connection via integrated cable tail or Ex d cable entry gland.



Stainless Steel Lumiglas Luminaire Type ESL 25-Ex with hinged bracket fastening, plain design, polished.

Electrical Connection

Connecting cable options:

a) Factory installed cable tail (2 m standard length) resin cast into trumpet cable entry gland, heat resistant up to 110°C.

Other cable lengths available: 5 m, 20 m.

b) Without factory installed cable: connecting cable to fit the cable entry gland (M20 x 1.5) to be provided by operating system company.

If ambient temperatures are greater than 40°C, heat-resistant cable e. g. Sinotherm 110 H05GG-F 3G 1.5mm² should be used.

Mounting options:

With circular sight glass fittings and flow indicators, the luminaire is secured to the cover flange by means of the hinged bracket. With screw-type sight glass units, the luminaire is mounted on the slotted cover nut.

The Lumiglas luminaire type ESL 25-Ex fits the following nominal sizes:

- a) Circular sight glass fittings to DIN 28120: from DN 50
- b) Bolt-On sight glass fittings to B16.5: from 1"
- c) Flow indicators: from 1"
- d) Weld-neck sight glass units to DIN 11851 (MV):
 - with DN 65, mounting is by way of separate flange adapter collar.
 - From DN 80 up, the hinged bracket is used.

For sterile applications, a version of this Lumiglas luminaire is available with a sleeve that fits over a raised lip on the cover flange.

Dimensions and Electrical Data for Lumiglas Luminaires Series ESL 25-Ex:

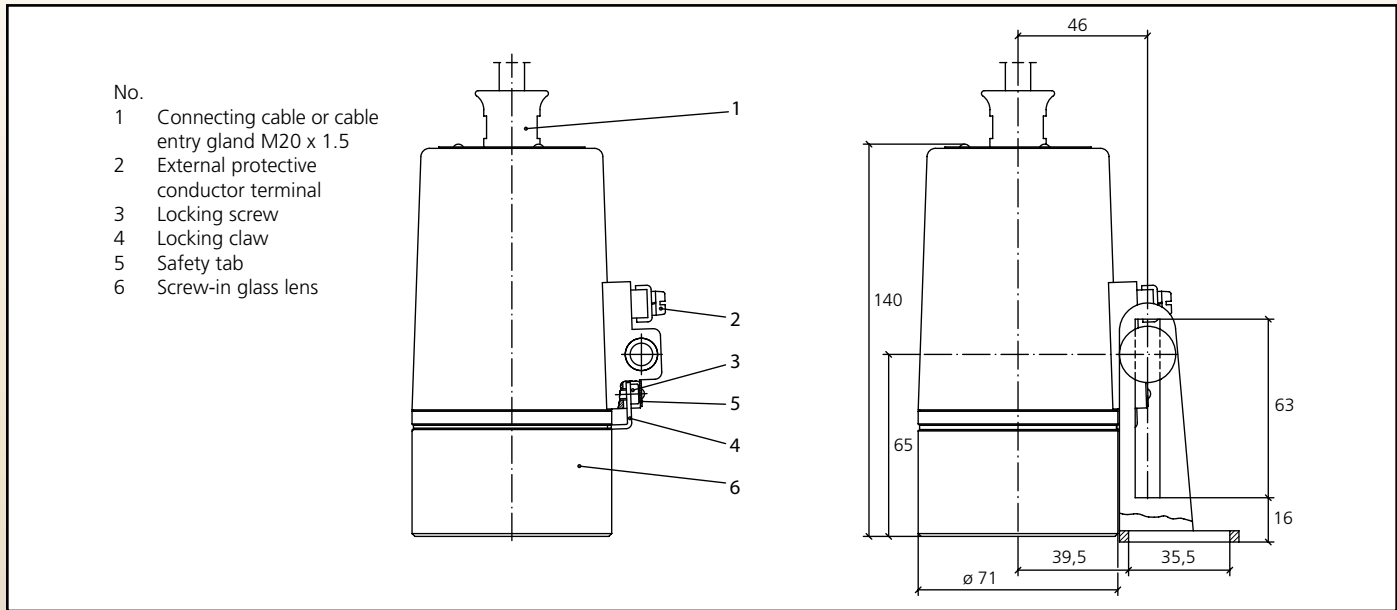

Components and Materials:

- Body of luminaire: 316 Stainless steel 1.4404, polished
- Fastening components: Stainless steel 1.4301 (see 'Accessories')
- Cable entry gland: M20 x 1.5

Weight (without connecting cable):

- Without internal transformer: 1.8 kg
- With internal transformer: 2.2 kg

Connecting Data

Temperature classification and electrical parameters (see also EC Type-Examination Certificate)

Item	Type ESL 25-Ex	Part No. ESL 25-Ex w/ conn. cable	Part No. ESL 25-Ex/1 w/o conn. cable	Voltage	Integral Trans- former	Halogen Lamp socket voltage		Ambient temperature range			
								-20°C ≤ T, ≤ +40°C	-20°C ≤ T, ≤ +60°C		
1	(12 V) 5 W	25E0-A1ANAN0N	25E1-A1ANANNN	12 ~	without	G4	12 V/5 W	2G T6	2D T80°C	-	-
2	(120 V/12 V) 5 W	25E0-A3ANAN0N	25E1-A3ANANNN	120 ~	with	G4	12 V/5 W	2G T6	2D T80°C	-	-
3	(230 V/12 V) 5 W	25E0-A4ANAN0N	25E1-A4ANANNN	230 ~	with	G4	12 V/5 W	2G T6	2D T80°C	-	-
4	(12 V) 10 W	25E0-A1BNAN0N	25E1-A1BNANNN	12 ~	without	G4	12 V/10 W	2G T4	2D T130°C	2G T4	2D T130°C
5	(120 V/12 V) 10 W	25E0-A3BNAN0N	25E1-A3BNANNN	120 ~	with	G4	12 V/10 W	2G T4	2D T130°C	2G T4	2D T130°C
6	(230 V/12 V) 10 W	25E0-A4BNAN0N	25E1-A4BNANNN	230 ~	with	G4	12 V/10 W	2G T4	2D T130°C	2G T4	2D T130°C
7	Cold lights (12 V) 20 W	-	-	12 ~	without	GU4	12 V/20 W	2G T4	2D T130°C	-	-
8	(12 V) 20 W	25E0-A1CNAN0N	25E1-A1CNANNN	12 ~	without	G4	12 V/20 W	2G T4	2D T130°C	-	-
9	(24 V) 20 W	25E0-A2CNAN0N	25E1-A2CNANNN	24 ~	without	G4	24 V/20 W	2G T4	2D T130°C	-	-

Installation examples:

As light port, fitted to a sight glass style DIN 28120, DN 50.



As light port, fitted to a MetaClamp® Sanitary Clamp connection



LJSTAR
INCORPORATED