

Lumiglas LED Luminaire Series USL 16-LED and USL 36-LED Stainless Steel

ISO 9001
DATA SHEET 02-0156 09/10

Perfect combination of a crevice-free stainless steel housing and LED technology:

This sight glass luminaire is designed for mounting on sight glass fittings for various applications. It is ideal for use in combined sight and light ports (single port version) or arranged separately (two port version).

The advantages of Lumiglas LED technology:

- Vibration and impact resistant
- High operational reliability (fit and forget technology)
- Continuous operation up to 50,000 hours (5-1/2 years)
- Green Technology with low energy consumption (9 Watts)
- No heat radiation into process vessel (cold light output)
- Optimal solution wherever fittings are difficult to access

Application:

The flush-designed housing with the latest LED technology is optimal for applications in hygienic environments such as the pharmaceutical, bio-tech and food processing industries. For illuminating bioreactors, mixers, filters and the interior of tanks, hoppers, silos, agitators, separators, pipelines and other – usually closed - containers in non-hazardous areas.

Compact design with powerful light output:

Glare-free illumination suitable for on use processing vessels, in-line sightglass and area lighting.

Lumiglas Luminaire types USL 16-LED and USL 36-LED fit the following nominal sizes:

- Circular Weld-On Sight Glass fitting to DIN 28120: from Size DN 40 (2" view diameter)
- Circular ANSI Bolt-On Sight window: from size 2"
- Visual Flow Indicators: from size 1"
- Circular Weld-Neck Sight Glass fitting series MV: from DN 50
- Sanitary Clamp Connection Series MetaClamp: from 1"

Protection:

- Dust and waterjet tight to NEMA 4 & 4X
- Dust and waterjet tight to IP 65 to DIN EN 60529/DIN VDE 0470 Part 1

Operating conditions:

Independent of internal pressure/vacuum in the vessel, Lumiglas luminaires of this type are approved for use in ambient temperatures of up to 90°C at the cable entry gland.

Under no circumstances should these luminaires be used for sealing vessel openings - an appropriate sight glass fitting must be used at all times.

Electrical data:

This Lumiglas luminaire is equipped with a factory mounted power cable of 3 meters.

Operating voltages:

- 24 Volt AC/DC LED Lamp 9 W with E27 Base
Momentary or permanent on/off switch with GU10 Base
- 120 Volt AC LED Lamp 9 W with E27 Base
Momentary or permanent on/off switch with GU10 Base



Lumiglas luminaire USL 16-LED with Mounting Bracket



Lumiglas luminaire USL 36-LED with MetaClamp Sanitary Clamp Connection

Momentary or Permanent On/Off Contact Switch:

Lights are designed for continuous use but can be equipped with an internal momentary or permanent on/off switch. Remote external switches and timers are also available.

Dimensions and electrical data for Lumiglas luminaires USL 16-LED and USL 36-LED:

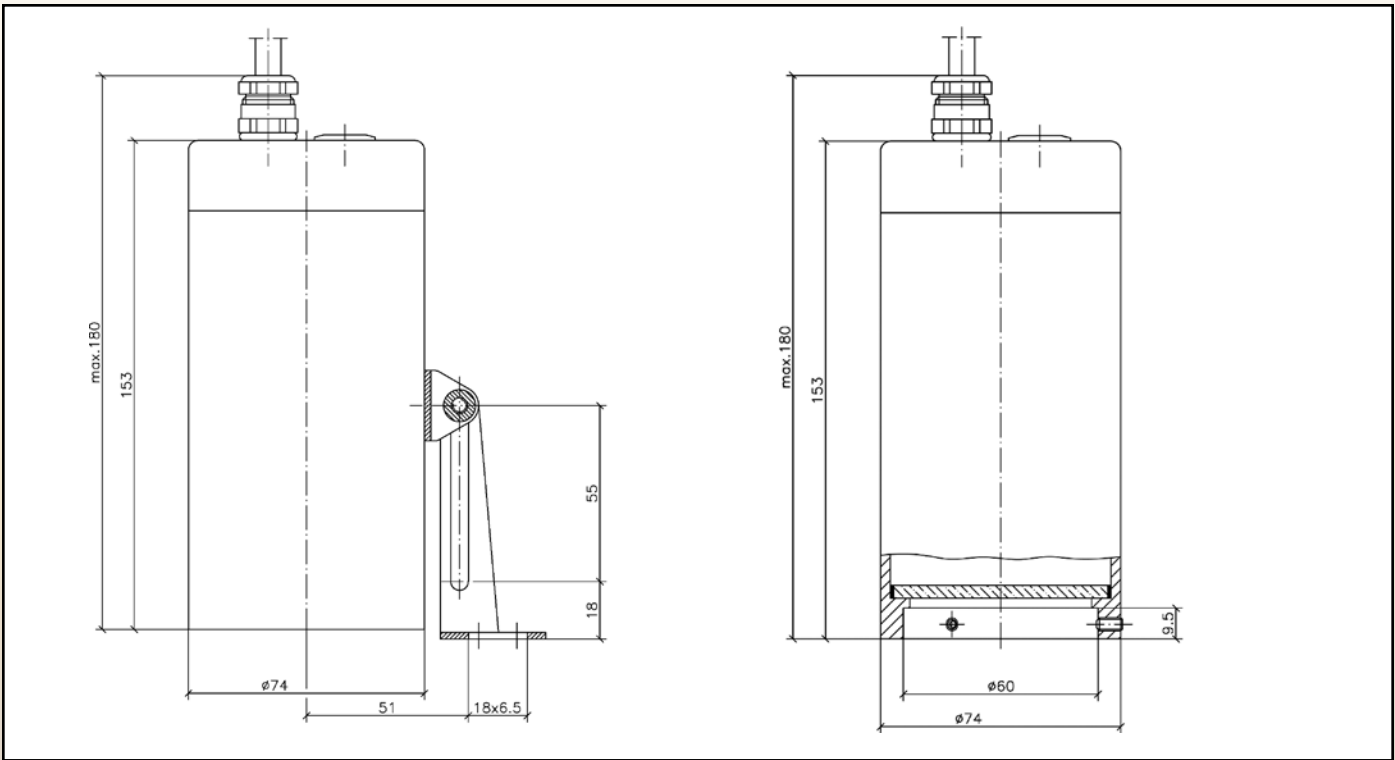

Components and Materials:

- Body and head of luminaire: 316 Stainless Steel (1.4404)
- Fastener Components: 304 Stainless Steel (1.4301) (hinged bracket or flanged adapter collar for attachment to weld-neck sight glass fitting MV sizes DN 50 & 65)
- Metaclamp sanitary clamp connection: Duplex Stainless Steel, Hastelloy or Monel with Borosilicate glass to DIN7080
- Connecting cable: 3 meter (3 x 0.75 mm²)
- Weight: 3 lbs. (1.4 kg)

Connecting data:

Lumiglas luminaires USL 16-LED and USL 36-LED					LED Lamp		
No.	Voltage	Pushbutton	USL 16-LED Part No.	USL 36-LED Part No.	Volt/Watt	Socket	Part No.
1	24 V	None	16LE-A2KNAN0N	36LE-A2KNNN0N	24V/9W	E27	BLB H9P20 E27
2	24 V	Momentary	16LE-A2K1AN0N	36LE-A2K1NN0N	24V/9W	GU10	BLB H9P20 GU10
3	24 V	Permanent	16LE-A2K4AN0N	36LE-A2K4NN0N	24V/9W	GU10	BLB H9P20 GU10
4	120V	None	16LE-A3KNAN0N	36LE-A3KNNN0N	120V/9W	E27	BLB N9P20 E27
5	120V	Momentary	16LE-A3K1AN0N	36LE-A3K1NN0N	120V/9W	GU10	BLB N9P20 GU10
6	120V	Permanent	16LE-A3K4AN0N	36LE-A3K4NN0N	120V/9W	GU10	BLB N9P20 GU10

Lumiglas luminaires USL 16/36-LED are suitable for mounting...

- With a fused Metaglas[®] sight glass for sanitary connections (MetaClamp[®]) for clamp fittings
- With a fused Metaglas[®] sight glass for aseptic weld-neck sight glass fittings, Series MV
- With a fused Metaglas[®] sight glass for TCI ClampConnect[®] and Bolt-Connect[®]
- With a fused Metaglas[®] sight glass for NA-Connect[®] fittings
- With a fused Metaglas[®] sight glass for VARIVENT[®] in-line housings

Ordering Information

Lumiglas Luminaire Stainless Steel USL 36-LED, 120V/9W,
PN: 36LE-A3KNNN0N



USL 16/36-LED with momentary on/off switch