

**Lumiglas Luminaire Series "Lumistar"**

- for use with circular sightglass fittings -

**Application:**

This luminaire is designed for integral light/sight ports to illuminate the internals of boilers, tanks, bunkers, silos, mixers, separators, pipelines and other vessels or reactors which are normally closed. This model is intended for use in all Non Hazardous Areas and it is suitable for food processing.

**Sightglass Styles and Size:**

This luminaire is designed to give glare free illumination on circular sightglasses Model DIN 28120 sizes DN 50 to DN 200 and SKS low pressure hinged units sizes DN 150 and DN 225.

**Protection:**

When correctly fitted, dust and waterjet proof to IP 65 and EN 60598.

**Ambient Condition Operating Range:**

The unit is independent of any internal vessel pressure or vacuum. It is suitable for temperatures of 80 °C at the cable gland.

**Electrical Data:**

- power supply 24 V (120 V on select sizes)
- 2-pin halogen lamp 20, 50 or 100 W
- 2-pin ceramic socket.

**Switch/Pushbutton(Momentary On/Off):**

Lumistar type luminaires are supplied with built-in pushbutton momentary on/off switch.

**Transformers:**

Transformers can be supplied optionally (separate units).

**Mechanical fitting:**

Lumistar is attached to the sightglass cover flange by two or four socket head screws, which come with the luminaire. The neck of the Lumistar housing extends to the sightglass disc. A ring seal with bridge is inserted between Lumistar housing and sightglass disc.

**Electrical Connection:**

Standard luminaire comes without cable. In that case:

- select correct type of cable to suit operating conditions
- select cable diameter to suit cable gland (M16 x 1.5)
- remove the screws which hold reflector and remove reflector
- pass cable through gland, fit bare ends into terminal block (Max. 2.5 mm<sup>2</sup>)
- tighten cable gland
- insert halogen lamp and reflector (see under "Lamp change")

Lumistar can also be supplied fitted with cable tail (extra).

**Lamp Change:**

- switch off the luminaire
- remove luminaire from cover flange. Caution! DO NOT loosen the hex nuts that hold the sightglass cover flange
- remove the screws which hold reflector and remove reflector
- withdraw defective lamp
- replace halogen lamp with lamp of same type and size, use protective cloth/paper to ensure bare fingers do not touch the glass, insert into 2-pin socket hole and gently but firmly push in
- check reflector for cleanliness and refit it
- check condition of bridge gasket and replace if defective
- refit luminaire with seal and reconnect power.



Lumistar luminaire, for installation on sightglass fittings

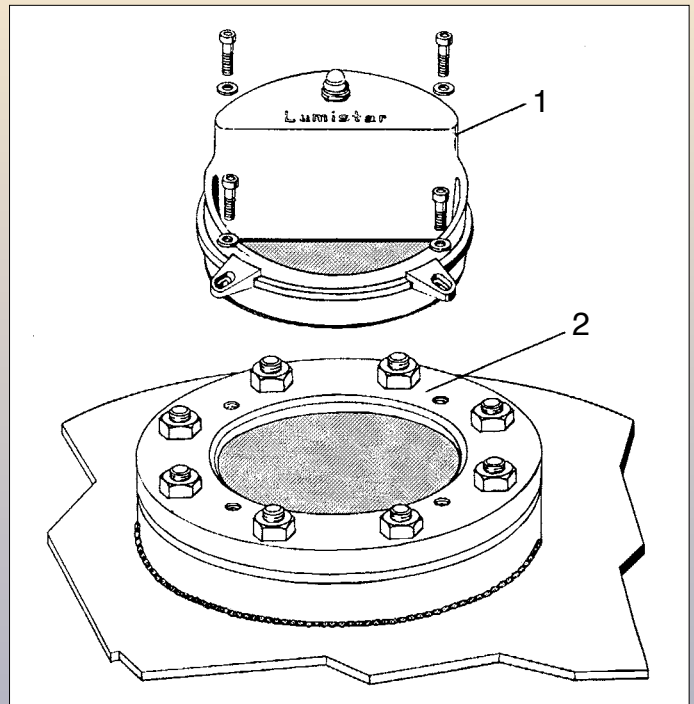

Lumistar luminaire (1) and DIN 28 120 sightglass fitting (2) of the corresponding size form an integral light/sight port

## Dimensions and electrical data of Lumiglas series Lumistar

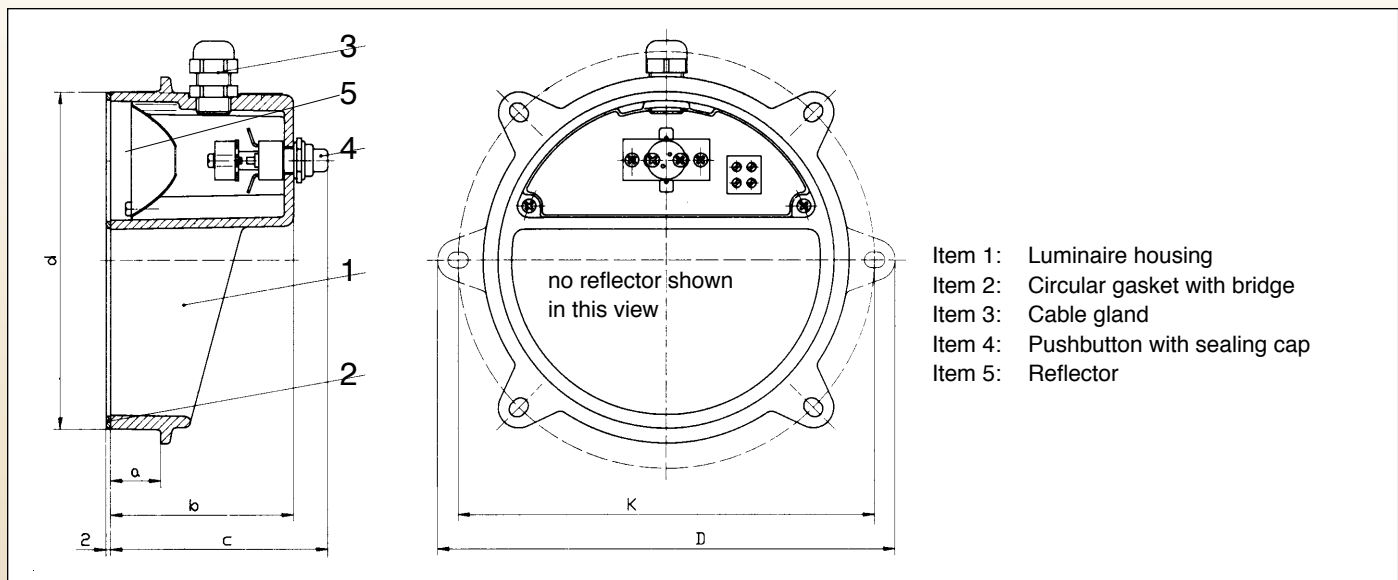

### Parts, Construction and Materials:

- Luminaire body: Corrosion resistant die cast aluminium, Paint finish: RAL 9007
- An integral pushbutton (4) for momentary use is standard.

All dimensions in mm unless stated otherwise. Subject to change without prior notice

Size		1	2	3	4	5	6
Luminaire type		<b>Lumistar 80</b>	<b>Lumistar 100</b>	<b>Lumistar 125</b>	<b>Lumistar 150</b>	<b>Lumistar 175</b>	<b>Lumistar 225</b>
Fits sightglass fitting to DIN 28 120 or similar	DN	50	80	100	125	150	200
Voltage (optional)	V	24	24, 120	24, 120	24, 120	24, 120	24, 120
Wattage (alternatively)	W	20	50	50,100	50,100	50,100	50,100
Fixing screw Bolt Circle	K	106	128	157	182	210	260-270
Dimensions	D	124	146	175	200	232	292
	d	77	97	122	147	172	222
	a	13	17	19	22	27	32
	b	65	75	77	80	85	95
	c	80	90	92	95	100	110
Fastening lugs: No./hole size		2 / 9x7	2 / 9x7	4 / 9x7	4 / 9x7	4 / 11x9	4 / 16x9
Fastening screws		M6 x 16	M6 x 16	M6 x 16	M6 x 16	M8 x 16	M8 x 16
Weight approx.	lb.	.66	1.0	1.1	1.2	1.8	3.0

### Ordering Information:

For example please state: Lumiglas luminaire type Lumistar 125, 120V - 100 Watt

- Wiper Type I can be used with Lumistar 125 and larger
- Lumistar lights are also available with LED technology

**LJSTAR**  
 INCORPORATED