

## Installation and Operating Instructions **CE** 0158

0093.094.00 c

### Lumistar Ex-Luminaire ESL 55-LED-Ex, Stainless Steel

**Ex** II 2G Ex d IIC T6 Gb  
II 2D Ex tb IIIC T80°C Db

**Important, please note:**

Sight glass luminaires are specifically designed and solely intended for mounting with or onto flanged sight glass fittings. Under no circumstances should sight glass luminaires be used as a substitute for the cover flange or to replace the complete sight/light port or as a lid or cover for vessel openings. Luminaires for use in potentially explosive environments must be mounted, installed and serviced by staff who have the relevant qualifications and have been properly trained for this type of work.

**Please observe the data set out in the EC type-examination certificate!**

Caution: Do not look into light – danger of impaired eyesight.

**General operating conditions:**

- Independent of pressure/vacuum in the vessel
- Approved for use in Ex environments:  
Gas: Zones 1 and 2; dust: Zones 21 and 22
- **Approved for use in ambient temperatures of between -20°C and +40°C**

**Electrical data, general:**

- Voltage, power, temperature class and protection rating are shown on the type plate.
- Ex approval acc. to EC type-examination certificate: BVS 09 ATEX E 169  
**Ex** II 2G Ex d IIC T6 Gb  
II 2D Ex tb IIIC T80°C Db
- The feed voltage is converted to the operating voltage for the LED illuminant by way of a power board installed in the luminaire.
- Power supply: AC or DC
- The luminaire is protected by a 1A miniature fuse on the internal power board.
- 10% voltage tolerance is admissible.

**Mechanical installation:**

The luminaire ESL 55-LED-Ex is suitable for the following nominal sizes, using the appropriate mounting attachment:

Type of fitting	from DN	Hinged bracket	Flanged adapter collar
Circular sight glass fitting			
DIN 28120	40	+	-
DIN 28121	40	+	-
Flow indicator	50	+	-
Screw-type sight glass fitting similar to DIN 11851	50	-	+
	65	-	+
	80	+	+
	100	+	+
	125	+	+

**Parameters/Temperature classification:**

ESL 55-LED-Ex Variant	Nominal Voltage	Ambient temperature range $-20^{\circ}\text{C} \leq T_a \leq +40^{\circ}\text{C}$	
		2G T6	2D T80°C
(24 V) 11 W	24 ≈	2G T6	2D T80°C
(120 - 230 V) 11 W	120 - 230 ≈	2G T6	2D T80°C
(24 V) 15 W	24 ≈	2G T6	2D T80°C
(120 - 230 V) 15 W	120 - 230 ≈	2G T6	2D T80°C



Lumistar Ex-Luminaire ESL 55-LED-Ex

**Mounting with hinged bracket:**

The hinged bracket is intended for attaching the luminaire to the cover flange of a circular sight glass fitting (or a sight glass in a flow indicator), or to the slotted cover nut on a screw-type sight glass fitting to DIN 11851. The hinged bracket is secured to the port of a circular sight glass fitting using the M8 screw included in the scope of supply. A blind hole needs to be provided in the circumference for this purpose. Alternatively, the hinged bracket can be welded in place.

**Mounting with flanged adapter collar:**

The flanged adapter is mounted using the slotted cover nut (DIN 11851):

- Place a suitable seal between the glass lens and the flanged adapter collar.
- Position the slotted cover nut and tighten.
- Insert the luminaire into the flange and secure.

**Please note:** The luminaire for sterile technology applications is fitted over the adapter collar of the special flange for sterile technology.

- Tighten the side retention screws.

• **Electrical connection:**

a) **ESL 55-LED-Ex with connecting cable**

- The connecting cable has already been works-fitted in the luminaire so that it is ready for use.
- The external protective conductor (2) must be connected to a separate operational earth.
- The cable needs to be secured after max. 1 metre.
- Caution! When replacing the cable (e. g. by one with a different length), the internal terminals must be loosened before the cable entry gland can be unscrewed.

**Conditions/requirements:**

This Ex-type luminaire has been manufactured with a permanently connected cable. The free ends of this lead must be installed in a category 2G/2D enclosure if connection is to be carried out in a potentially explosive environment.

The luminaire and the area around the place of installation should be cleared of dust prior to installation and in the course of maintenance work.

The dismantled parts should be protected against dirt, dust and contamination during installation or servicing work. When closing the luminaire, special attention should be paid to ensure that the interior of the lamp is free of dust.

b) **ESL 55-LED-Ex with cable entry gland (encapsulated)**

- Select a connecting cable to fit the M20x1.5 cable entry, taking account of the diameter of the cable (8-11 mm).
- The minimum temperature resistance of the connecting cable must be observed (-20°C/+85°C).

c) **ESL 55 LED-Ex (tested combination)**

**Only** the following cable entry glands and cables should be combined:

Cable gland types	Installation torque	
HSK-M-Ex-d, Part No. 9103.124.00 M20x1.5 nickel-plated brass (by Hummel)	7.0	2.5
KU1BPM20-Ex-d-Alpha X, Part No. 9103.131.00 M20x1.5, stainless steel (by RST)	6.0	3.0

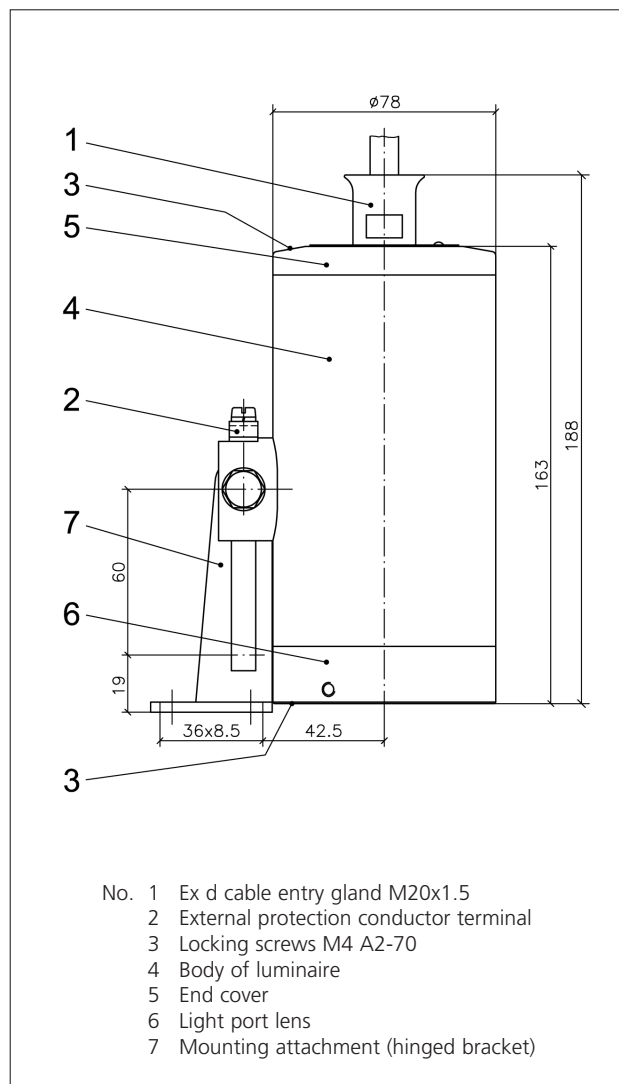

- No. 1 Ex d cable entry gland M20x1.5  
 2 External protection conductor terminal  
 3 Locking screws M4 A2-70  
 4 Body of luminaire  
 5 End cover  
 6 Light port lens  
 7 Mounting attachment (hinged bracket)

Cable types
EVA flexible sheathed cable, Sinotherm 110, Part No. 3403.017.00, 3x1.5 mm <sup>2</sup> , Ø 8.5 mm
Ölflex Heat 180, Part No. 3403.045.00, 3x1.5 mm <sup>2</sup> , Ø 8.9 mm
Ölflex Heat 180, Silflex UR-AWG18, Part No. 3403.044.00, 5x1.0 mm <sup>2</sup> , Ø 10.3 mm
Ölflex Classic 110 black, Part No. 3403.051.00, 3x1.5 mm <sup>2</sup> , Ø 10.1 mm

• **Caution:**

The locking screws for the end cover (M4x12) and light port lens (M4x25) must have a yield strength of  $\geq 240$  N/mm<sup>2</sup> (A2-70).

• **Please note:**

Fastening elements should be ordered separately, if required.

• **Replacement parts**

	Part No.
End cover	0821.011.00
Light port lens (light aperture)	1773.013.00
Cable entry gland (Ex d M20x1.5) stainl. steel	9103.133.00
O-ring seal	0862.090.00
Grub screw	7446.075.00
Cylinder head screw M4x12 A2-70	6911.358.00
Cylinder head screw M4x25 A2-70	6911.218.00
Flared cable entry gland...	
complete with 2 m connecting cable	1084.021.00
complete with 10 m connecting cable	1084.024.00

• **Servicing:**

- Keep luminaire clean.
- After opening the luminaire, the surfaces of the cylindrical gap between the end cover (5) and the light port lens (6) should be cleaned. Before assembling the luminaire again, check that the components are undamaged and relubricate them (e. g. with AEMA-SOL 6 B, from A.E. Matthes).
- Please use original replacement parts only.

• **Warning:**

- The body of the luminaire and the end cover should not be interchanged with other parts of this series.