

CROSS-BOLTED ARRANGEMENT

ASSEMBLY IS DIFFICULT BECAUSE ONE SIDE – INCLUDING CUSHION, GASKET-GLASS, RETAINER AND BOLTING – MUST BE HELD IN POSITION WHILE THE OTHER SIDE IS ASSEMBLED. MAINTENANCE IS TRICKY TOO, SINCE GLASS OR GASKET REPLACEMENT ON ONE SIDE REQUIRES MAINTENANCE OF GASKET SEAL INTEGRITY ON THE OPPOSITE SIDE.

THE LONG CROSS-BOLTS, WHEN EXPOSED TO AN INCREASE IN TEMPERATURE, WILL INCREASE IN LENGTH. THIS WILL REDUCE COMPRESSION ON THE GASKET AND LEAKAGE CAN RESULT. CONVERSELY, COOLING WILL SHORTEN THE BOLTS, COMPRESSING THE GASKET, AND SUBSEQUENT HEATING WILL EXPAND THE BOLTS, POSSIBLY COMPROMISING THE INTEGRITY OF THE COMPRESSED GASKET.

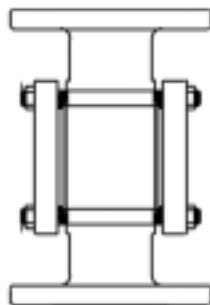

INDEPENDENTLY BOLTED ARRANGEMENT

ASSEMBLY IS EASIER, BEING DONE ONE SIDE AT A TIME. MAINTENANCE IS ALSO EASIER SINCE EACH SIDE CAN BE DONE SEPARATELY.

RELATIVELY SHORT BOLTS MEANS LESS CHANGE IN LENGTH WITH AN INCREASE IN TEMPERATURE, THE CHANGE BEING DIRECTLY PROPORTIONAL TO THE ORIGINAL LENGTH OF THE BOLT.

THERE IS ALSO LESS REDUCTION IN LENGTH FROM COOLING, WHICH MEANS LESS LIKLIHOOD THAT THE GASKET INTEGRITY WILL BE COMPROMISED.

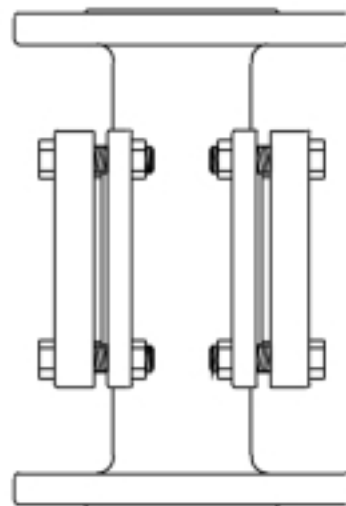

REV.	DESCRIPTION OF CHANGE	DATE	NAME

**INDEPENDENTLY BOLTED
RETAINERS
VS
CROSS BOLTED**

L. J. STAR INCORPORATED
P.O. BOX 1116
TWINSBURG, OH 44087
(330)405-3040 • FAX (330)405-3070

CERTIFIED:
DATE: DECEMBER 2 1999
PART NO.
DRAWING NUMBER
ENG-001