

# Spray Ring For Sight Glass Assembly

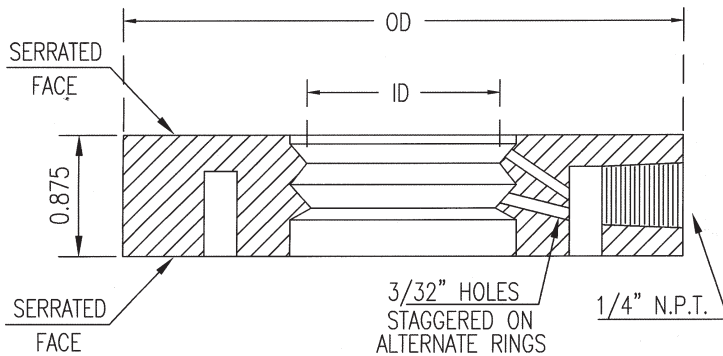

DIMENSIONS				
ANSI Flange Size	150 PSI Spray Ring OD	300 PSI Spray Ring OD	Spray Ring ID	Number Spray Holes
2"	4.000	4.250	1.688	8
3"	5.250	5.750	2.625	8
4"	6.750	7.000	3.563	16
6"	8.625	9.750	5.500	16
8"	10.875	12.000	7.438	16

The L.J. Star spray ring provides high pressure, 360 degree sight glass cleaning to remove solids and liquids that curtail clear vision.

Inserted between the connection flange and the sight glass assembly, the spray ring is fed high pressure rinsing fluid through a 1/4" NPT inlet and distributes it radially through a series of spray holes along the inside circumference of the ring. The spray holes are angled independently to clean the entire surface of the sight glass. The spray ring accepts liquids compatible with the product, or in the case of powder removal, high pressure gases can be used such as air, nitrogen, carbon dioxide, etc.

The spray ring is easily adaptable to automatic timed interval cleaning as well as manual valve operated cleaning.

Standard materials of construction include stainless steel and carbon steel. Hastelloy®, aluminum, titanium, Monel®, Teflon® and FRP materials are also available.

The L.J. Star spray ring fits flange sizes from 2" to 8" for ANSI Classes 150, 300, and 600.

For additional information and applications assistance contact:

**L.J. Star Incorporated**  
**P.O. Box 1116, Twinsburg, OH 44087**  
**Phone: (330) 405-3040 • Fax: (330) 405-3070**  
**Web Page: [www.ljstar.com](http://www.ljstar.com)**  
**e-mail: [view@ljstar.com](mailto:view@ljstar.com)**

